

Journal of the British Society of Scientific Glassblowers

VOL. 1

JUNE, 1964

No. 2

EDITORIAL

WHAT IS THE DEFINITION OF A SCIENTIFIC GLASSBLOWER ?

WITH the formation of a sub-committee to look into the standard of qualification which could be established for a certificated grade of membership, it is apparent that the above question must be asked.

With so many types of glassworker involved, each thinking they have claim to the title, some attempt at definition has sooner, rather than later, to be made.

Let us review the types of worker in the glass industry:

(1) *The furnace or pot glassblower.*—He was the original glassblower, responsible for the first articles of glassware used in scientific work, and who is, today, still the basic worker in the industry.

(2) *The lampworker.*—He works mostly at a bench and is the backbone of commercial glassworking concerns, being a highly skilled glass manipulator.

(3) *Glassworking operatives.*—These are engaged in mass-production glassworking processes not requiring extensive skill and experience.

(4) *Specialist operatives.*—Those who produce such items as joints, stopcocks, metal/glass seals, etc., on a repetitive basis.

(5) *The research glassblower.*—He is able to cover the work of all the preceding categories with the exception of the first one, thus making a research establishment potentially independent of commercial glassworking concerns. The advanced glassblower in this class is also involved with design, modification and maintenance, in addition to actual construction.

The Society welcomes as members all those who are in the broadest sense connected with glassworking, recognising the great skills needed in many of the associated fields of glassworking. However, the Society is primarily for glassblowers, and many of the specialised operatives do not come into this classification.

In view of the broad type of potential membership, it would seem that more than the existing grades of membership are needed. It would be undesirable to have too many grades but, in order to maintain some measure of comparability, it would seem that the specialist operator should be in a category of his own. By virtue of his own specialist skill his status is already determined.

The craftsman glassblower, for whom the Society was founded, must likewise have his own grade, but at the moment there is no procedure for recognising his skill.

What more natural, therefore, than that some standard should be set, indicative of the ability of the particular grade of member, to be recognised by the Society.

When the sub-committee finally makes its report to the Council it is to be hoped, for the sake of the status of future glassblowers, that decisions will be made in keeping with the aims of the Society, to emphasise the value of craftsmanship.

Most of us would agree, no doubt, that craftsmanship has been the proud heritage of the British for many a long year. It is to be deplored that this craftsmanship should appear to be on the wane, being replaced by mass-production methods in practically all fields. Even in the field of glassblowing we find that the workers are becoming more and more specialised and that many who should be research glassblowers are becoming, in many cases, mere assemblers of commercially made components.

The First Issue

In response to the first issue of this Journal, we have received a great deal of encouragement and, indeed, the Council's decision to publish it was well justified by the reaction the Journal has caused.

British Society of Scientific Glassblowers

Founded 1960

Chairman

S. G. YORKE
Grove House, Longton Road
Stone, Staffs

Hon. Treasurer

D. A. HENSON
3 Oliver Drive
Calcot, Reading

Hon. Secretary

I. C. P. SMITH
65 Woodberry Way
Chingford, London, E.4
SILverthorn 3295

COUNCIL MEETING

A COUNCIL Meeting was held on Saturday, 11th April, 1964, at Birmingham College of Advanced Technology with Mr. S. G. Yorke as Chairman. The meeting started at 11.30 a.m. and continued until 5.30 p.m. Sixteen Councillors attended and apologies were received from five.

Council really got down to it, the only pause, and that a short one, was when sandwiches were eaten and coffee drunk at the Council table. In a short summary of this kind it is only possible to mention briefly some of the business transacted.

Officers' reports

The secretary reported that he had been kept very busy indeed, mostly with new members, 46 had been handled since the last meeting.

The treasurer reported that the membership is now 209, a few have not yet paid their subscriptions.

The P.R.O. reported one post for a glassblower to be advertised in the Journal. He was given authority to approach the Institute of Science Technology with a view to possible future collaboration on propaganda at British Association meetings.

Section reports

Reports from six sections were read, all had held meetings, some reported regular monthly meetings, several had organised works visits and two were still putting their house in order.

Journal

General satisfaction was shown for the first issue of the Journal. Several letters from members were read, all of them congratulatory, and Council thanked the Editors for their efforts. There was considerable discussion about the Journal and many points of both present and future policy were raised; for example, the Journal will try to provide an information service and increase in size, a journal abstracting

service has been started and 91 journals are being covered, this number will be increased as more abstractors are found.

Rules

Rules were discussed and, finally, a proposal to set up a rules sub-committee, with a representative from each section, was accepted. Each section is to inform the chairman of this sub-committee, Mr. J. Price, of the name and address of its nominee.

Education

Mr. D. W. Smith presented the report of the Western Section to Council but no other section had as yet produced a report. Council approved a motion in favour of a practical certificate of competence. An education sub-committee was set up to receive reports from sections, consider them and present a unified plan to the next meeting of Council. The sub-committee consists of Messrs. Yorke, Butler, Edkins, Evans, Priem, D. W. Smith and I. C. P. Smith.

1964 Symposium

Will be held on 18th September at Bristol University. The theme will be "Silica" and there will be lectures, demonstrations and exhibits.

Any other business

It was suggested that the next Annual General Meeting be held on a Saturday and be preceded by a talk from a guest speaker.

The next Council Meeting will be held on the 4th July in Birmingham.

J. A. FROST
P.R.O.

The Journal is published quarterly by the B.S.S.G. and is available free to members and at 5s. per copy (or 17s. 6d. per annum) to non-members. Editorial communications should be addressed to the Editors, c/o Departments of Physics and Chemistry, University of Bristol, and enquiries for advertising space to Mr. I. C. P. Smith, 65 Woodberry Way, Chingford, London, E.4. Printed in Great Britain by E. G. Ellis & Sons, Willow Street, London, E.4.

© B.S.S.G. and Contributors, 1964

THE MINISTRY OF LABOUR TRAINING SCHEME

Little is known of apprenticeships and training schemes for glassblowers carried out by various organisations in this country. We therefore invite articles covering this field and the following is the first response

NEON sign glassblowing was started by the Ministry in approximately 1930 at Watford Government Training Centre and, I believe it is true to say, that a large number of present-day glassblowers emanated from classes of those days.

The intervention of the Second World War meant a break in the scheme, but the Neon Sign Course was reopened in September, 1946, when I was appointed as the instructor. Unfortunately, in early 1947, at the precise time the first lads were "due out," came the Fuel Crisis and it was only with special efforts that we were able to place those lads into "Scientific Glass" as opposed to "Neon." It was then decided to include a fifty-fifty share of neon and scientific glasswork into the syllabus and that was the pattern for the next 18 months or so and placings were quite steady.

By 1949 the course had become completely scientific, but always (and it still stands) with the proviso that an employer could request some special training for the prospective employee that he may have selected.

After the Second World War the type of applicant coming forward for training was generally young and readily adaptable, and I am happy to be able to say that a fair number of the members of the British Society of Scientific Glassblowers (indeed one member of the Committee) received their training under my supervision at Waddon Training Centre. Today, with full employment the rule, it is more difficult to get good applicants but our standards of training have remained high.

The course at Waddon is of 26 weeks' duration, and commences with "point pulling" in 10 mm. Pyrex rod, which enables the trainee to gain a little confidence, a build-up which is certainly needed when he is put on to soda glass in the second week or so. For 12 weeks or thereabouts various simple exercises, such as bends, joints, seals and small bulbs, etc., are practised, with varying degrees of success, on

small tubing until at about 14 weeks an attempt is made at a U.C. filter pump. Then follow a series of exercises, each becoming progressively more complicated and on larger tube, until at 20 to 22 weeks the trainee is able to go over to Pyrex work with a reasonable degree of confidence and success.

Individual and group instruction is practised and I feel that the trainees progress much better if they are able to realise and conquer their own shortcomings with only a minimum of guidance. A series of lectures (one hour per week) is given, covering many aspects of the glass industry generally, as well as dealing with Elementary Glass Technology, Lamp and Valve Work, i.e., Glass to Metal Seals, Lathe Work, Vacuum Work, etc.

I would confidently say that, given the right type of individual, we are able to provide him with the equivalent of what he might learn outside in, say, three years. We do not, of course, try to train those who prove to be below trade requirements—they are either discharged or transferred to a different trade during the first few weeks. I have trained many lads since 1946 and, although I can (thanks to the grapevine) pin-point about 120, there are no doubt a number employed in various places that I am unaware of, perhaps if they see this they may be persuaded to drop me a line and let me know how things are going!

What of the future? My own view is that it would be helpful if a First Year Apprenticeship Course could be provided, such as the Ministry of Labour are now running in the engineering, electrical and radio and T.V. servicing trades, but this will need the support of employers in general and this Society in particular.

All too little is done today to attract the young blood into the craft, and I am constantly amazed by the number of visitors who remark "I never realised that so much could be done with glass."

T. E. PARSELL
Instructor

HIGH FREQUENCY ELECTRICAL HEATING OF GLASS

Talk given to Western Section on 24th March, 1964, by S. G. Yorke

GLASS is normally accepted as an insulator, at low temperatures with a clean dry surface it is among the finest insulating materials, having a specific resistance up to 10^{19} ohms. The resistance or, conversely, the conductance of glass depends on the composition, especially the alkali content and the humidity which may be responsible for a surface increase in conductivity.

Change in temperature has an intense effect on the electrical conductivity of glass. From room temperature to around $1,200^{\circ}\text{C}$ the resistivity may range from 10^{19} ohms to 1 ohm. To get some idea of this temperature effect, the specific resistance at 25°C may be of the order of 10^{19} ohms: 100°C — 10^{12} ; 250°C — 10^8 ; 400°C — 10^6 ; 600°C — 10^4 ; at $1,000^{\circ}\text{C}$ — 10^2 and around $1,200$ or higher may be at unity.

Various workers, about the late 1920s and the early 1930s, investigated the effects of high-frequency electricity on glass. Conclusions were somewhat divided as to whether heating resulted from dielectric breakdown or from ohmic heating. Corning Glass Co. of America did much of this early work. Originally the interest was to treat the glass as a dielectric and to apply the H.F. as dielectric heating. It became apparent that the glasses would conduct high voltage as high frequencies if the glass was raised to a reasonable temperature. Conditions were then established where, at a temperature well below the fusing range of glass, the resistance was sufficiently low to allow a practical high voltage to be conducted through it. Thus was electrical heating of glass achieved.

The spark-gap oscillator (pioneer of radio transmission), is the type of equipment used for high-frequency glass-heating. These units are built to varying powers from 5 to 20 kVA or larger. One of the early units built at Q. & Q. operates on 440 volts and is designed for three ratings, 10, 15 and 20 kVA, giving output voltages from 15,000 to 60,000. The construction is robust and the circuit fairly simple. It requires little maintenance except for cleaning and readjusting the gap units and this can be done by unskilled personnel.

This oscillator produces a frequency between 100 and 250 kc/s which is within the satisfactory range for glass-heating. Another important feature of the equipment is that the input power is relatively unaffected by the demand on its

output. When considering the variance of the resistance of glass through the working temperature range, this can well be appreciated; dropping from about 10^6 ohms at 400°C to nearly unity at $1,200^{\circ}\text{C}$.

Several advantages are realised by the use of electrical heating of glass. The heating is the result of the conductance in the glass and the heat is not merely concentrated on the surface prior to thermal conduction into the glass as it is with conventional flame heating.

Characteristically the electrically heated path is narrow and almost immediately this path becomes almost white hot. To achieve similar conditions by gas heating would result in boiling the surface of the glass. It is true that excessive electrical power will also boil the glass.

The conducting "hot path" being narrow, it is ideal for joining short ends of ground joints or flanges to flasks or other joints without distorting the ground surfaces, for sealing in sintered plates, beading edges and for Dewar seals.

To the glass apparatus manufacturer, the importance of this technique lies in the speed of the actual operation. For example, to join a 100 mm. flange to a 20-litre flask takes just over a minute. This advantage is, of course, lost in industry if the preparation for the operation is too lengthy. To this end, every contributory operation must be cut to a minimum, the heating burners have quick-operating, pre-set valves to eliminate human error in operation. Two important and relatively lengthy operations are pre-heating and "letting-down" the glass before and after joining. The former can be automatic and executed whilst the operator is conducting some other stage in the process. The "letting-down" of the joint is vitally important, as one can readily appreciate that, after such local intense heating, there are terrific stresses remaining at the join. A certain amount of flame treatment is necessary prior to the article being deposited into an oven convenient for the operator.

Coal-gas oxygen burners are being used for the initial heating. Copper jets are used of about 1 mm. bore, usually being diametrically opposed across the glass. The jets can be used as the electrodes when they are insulated from the burner carriage, or secondary electrodes or

carbon may be used independently to the burners to conduct the H.F. into the heated glass. The H.F. may either be used as the primary process in joining the glass or as a supplementary heater to the flame heaters.

There are a few precautions which the operator is instructed to observe in the use of the H.F. unit. The flame from a hand-held torch must not be directed onto the glass during the electrical heating, since the electricity will conduct through the flame, the burner and through the operator to earth. The same applies to the use of metal or carbon forming tools, unless sufficiently well insulated. At these voltages and frequencies high-grade insulating materials must be used, and even these materials break down if allowed too near the flame—once "tracking" has occurred, the leak path will persist across the insulator.

The electrical discharge from the jets takes a preferred path, which of course should be the hot glass. If the voltage is too high it will conduct through the gas envelope around the hot glass, or if the metal chucks and fittings are too close it will strike through them to earth. The chucks are equipped with insulating ceramic jaws, or metal jaws may be enclosed in silica tubes. The jets are mounted on insulated pillars or boards and connected with rubber tubing for the gas supply; they are of the pre-mixing type and, should they on occasion backfire, the chances are that the inside of the tubing will be charred, then becoming the preferred path for the electricity—a condition indicated by persistent backfiring.

All machines and fittings used with H.F. units must be efficiently earthed. The unit must also be efficiently suppressed against H.F. back-leakage into the mains, and against giving radio interference. The unit and equipment have built-in safeguards against accident and mis-handling.

The spark-gaps are the components of the unit which require most maintenance. The faces must be kept clean and fairly accurately spaced to about 0.005in. They need efficient cooling, since the efficiency of the unit to a large extent depends on the "quenched" of the sparks. The cooling may be circulated distilled water or cold air by far or compressed air system. The original gaps used at Q. & Q. had tungsten faces; these were both expensive and costly to machine, for re-surfacing and adjustment were by means of set-screws, which was a very tedious job. Silver gaps were then introduced which were about a quarter of the price of tungsten and more readily machined, but still had the screw adjustment. The latest design is the annular silver face, mounted in stacks and spaced with selected mica discs. Compressed air is blown through the central hole to be forced out between the faces. These are more easily cleaned and require no adjustment except to check the thickness of the mica spacers. The tungsten faces were silver-soldered to the copper plates, which was a rather exacting job, whereas the silver faces are soft-soldered with a special silver-loaded lead type of solder. S. G. YORKE

THE USE OF GLASSWORKING LATHES

Talk given to Southern Section on 18th March, 1964, by J. H. Burrow

MR. John Burrow, of the University of Bristol, was the guest speaker at a meeting of the Southern Section, held in the Main Lecture Theatre, Chemistry Department, Queen Elizabeth College, Campden Hill Road, on Wednesday, 18th March, 1964. Although aware of the extensive use of glassworking lathes in industry, the lecture was confined to their use in research work, where a variety of jobs are required rather than repetition of single items.

The standard lathe normally consists of a sliding head and tailstock, a fire carrier, good stopping and starting control (which may include a clutch), and a wide-range, variable speed drive. Of major importance is that all controls should

be easily accessible without diverting attention from the glass being worked. This last requirement would lead to consideration of remote control on the headstocks of the longer lathes which are being introduced in some laboratories.

A brief review of the historical development of glassworking lathes points to the flexibility of modern machines. In the twenties the formation of the valve industry led to the introduction of lathes on which large, copper-glass anode seals could be made and also drop-sealing of filaments and grid assemblies. Thus the tipping, dual-purpose lathe was developed and later, due to the growth of the television industry, modified to perform work of a more general nature.

Up to 1939, however, there were few lathes in research laboratories. During the thirties more general glassworking lathes were developed by Litton and Eisler in the U.S.A., so that the unskilled research worker could fabricate his own glassware. The Litton machine became more popular and a few were imported into England just before the war, serving as a pattern from which British development progressed and has now become superior.

With symmetrical work, a better and more reliable finish was achieved, whilst micro-glassware and working with silica were made easier. For working large diameter tubing, multiple burners were introduced and have gradually improved in design. Comments were then made on types of multi-jet burners in use, beginning with the development of adjustable "surface-mix" burners originally American in origin and designed for use with natural gas, but now made in England in a much more durable form.

The speaker, however, indicated his preference for simple ring-burners in order to heat no more glass than necessary. It is essential, however, to have not only a series of burners to accommodate all sizes of glass, but also a quick-change system; either a simple, finger-tight union or a plain taper may be employed. Some vertical movement of the burners is desirable. For most cases this type of burner, in conjunction with a hand torch, is the most economical, although for repetition work special burners may be superior.

For all types of burner systems it is essential to have large enough supply pipes, e.g., $\frac{3}{4}$ in. diameter gas to the lathe and $\frac{1}{2}$ in. diameter through the burners. A gas booster should then be considered in cases where insufficient gas is available.

The size of the glass being worked is the main factor governing the arrangement of burners. For small symmetrical work up to $\frac{1}{2}$ in. diameter, the best results are still obtained with a simple burner, whilst work up to 6in. diameter may be easily worked with multiple-jet burners, with reasonable flexibility for other operations. As the size being worked increases the machine becomes more limited in scope. At about 8in. diameter it is possible to make a join, flange and a Dewar seal, but at 12in. diameter the lathe is merely a joining machine and becomes an industrial rather than a research tool.

Some aspects of lathe-working differ from bench burner practice. In the latter case the hands perform the turning, stretching and pushing required, whilst the pressure of the flame and blowing aid the shaping operation. Although blowing can often be usefully employed on a lathe, with larger sizes the pressure fluctuations necessitate blowing and sucking for control, and it is often better to use centrifuging as an alternative. The main advantage, however, is that, with the hands partially freed, it is possible to paddle the glass into the required shape by means of suitable graphite tools. With the use of stops, it is possible to operate mechanically for the production of repeatable sizes. A further arrangement may be made so that the lathe is set to paddle whilst the glass is blown or centrifuged up to it. When repeatable shapes are required, a profile cut in graphite may be employed.

In conclusion, it may be helpful to bear the following points in mind when using a glass-working lathe:—

- (1) As much time as needed should be spent in setting up the lathe, so that the operation itself requires the minimum of time.
- (2) The glass should be really hot to avoid internal crevices, e.g., in ring and Dewar seals.
- (3) During working, the general temperature should be rising so that pre-heating of large items is obviated.
- (4) Finishing flame-annealing should be carried out by observing the difference in reflectivity between worked and unworked glass.

The talk was supplemented by films made at various times at the University of Bristol. The first illustrated various lathe operations, such as constructing and doming tubes, spinning flanges and plating. The second showed the manufacture of a double-tailed helium Dewar involving the re-forming of blanks and tubes to obtain the correct sizes and accurately straight and cylindrical tails.

The final film showed two methods of making globular Dewar flasks, one very old (1930) where the inner flask was blown by hand into the outer and the neck joined, and a more recent one (1950) showing how, by splitting the outer and rejoining, a better result can be obtained by using a lathe.

ABSTRACTS

APPARATUS—CHEMISTRY

- (1) **The Analysis of ^{14}CO — $^{14}\text{CO}_2$ mixtures by Gas-Chromatographic Separation and Aqueous Solution Counting.**
CLULEY, H. J. & KONRATH, J. H. *Analyst*, Vol. 88, 1963, 761-770.
Details given of gas-sampling system—and of trap for freezing CO_2 .
- (2) **Zone Electrophoresis in Columns of Agarose Suspensions.**
HJERTEN, S. J. *Chrom.*, Vol. 12, No. 4, 1963, 510.
Gives details of the apparatus, this includes a shunt of the electrophoresis tube.
- (3) **Simple Apparatus for Streaming Potential Measurements.**
LEWIS, A. F. *et al. Lab. Pract.* Jan., 1964, 50-51.
Details given of the apparatus, channelling and other effects being eliminated or reduced.
- (4) **A microreactor—Gas Chromatographic method for the identification of Polymeric Materials.**
COX, B. C. & ELLIS, B. *Anal. Chem.*, Vol. 36, No. 1, 1964, 91-95.
Gives details for the construction of the microreactor.
- (5) **Apparatus for Determining Weight Loss in an Inert Atmosphere.**
HOLOVKA, J. M. *Anal. Chem.*, Vol. 36, No. 1, 1964, 255-256.
Details given for building the apparatus and its use.
- (6) **Changes in Official Methods of Analysis Made at the Seventy-Seventh Annual Meeting, October 14, 15, 16 and 17th, 1963, 11. Beverages: Wines, Cash Electric Still.**
J.A.O.A.C., Vol. 47, No. 1, 1964, 180-181.
Gives details of the apparatus and its method of use.
- (7) **Modified Combustion Pipette to Analyse Explosive Mixtures of Methane with Air in Holdane Mine-Air Analysis Apparatus.**
GHOSH, A. K., MITRA, B. *Chem. & Ind.*, February 15th, 1964, 269-270.
Gives detailed drawings for fabrication of the pipette and explains use.
- (8) **Automatic, Amperometric, Cupferron Titration of Zirconium in Highly Radioactive Solutions.**
KUBOTA, H. & SURAK, J. G. *Anal. Chem.*, Vol. 35, No. 11, 1963, 1715-1718.
Details of apparatus given.
- (9) **A Conductimetric Micro Method for the Simultaneous Determination of Carbon and Hydrogen in Organic Compounds.**
GREENFIELD, S. & SMITH, R. A. D. *Analyst*, Vol. 88, Nov., 1963, 886-890.
Details of apparatus given.
- (10) **Determination of Hydrogen in Sodium by Isotopic Dilution with Tritium.**
EVANS, C. & HERRINGTON, J. *Anal. Chem.*, Vol. 35, No. 12, 1963, 1907-1910.
Details of apparatus given.
- (11) **Differential Dielectric Apparatus for Determining Water Added to Solvents.**
WOLFE, W. C. *Anal. Chem.*, Vol. 35, No. 12, 1963, 1884-1887.
Details of apparatus given.
- (12) **Dry Nitrogen Gas: Simple Laboratory Production.**
ROBERTSON, J. H. J. *Sci. Instrum.*, Vol. 40, No. 10, 1963, 506-507.
Details of apparatus given which produces dry nitrogen by boiling liquid nitrogen by means of electrical heat.
- (13) **A Microanalytical Sampling Technique for Hygroscopic Liquids.**
MAGUIRE, D. A. *Chem. & Ind.*, October 12th, 1963, 1655.
Technique and apparatus for filling phosphate glass ampoules with hygroscopic liquid samples.
- (14) **A constant Head Device for Chromatographic Columns.**
FORD, M. A. *Lab. Pract.*, Vol. 12, No. 12, 1963, 1093.
Describes the construction of a feed head for columns.
- (15) **Determination of C_5 to C_{11} n-Paraffins and Hydrocarbon Types in Gasoline by Gas Chromatography.**
ALBERT, D. K., *Anal. Chem.*, Vol. 35, No. 12, 1963, 1918-1921.
Details of apparatus given.
- (16) **Determination of Partition Coefficients at Infinite Dilution by the Gas Chromatographic Analysis of the Vapour above Dilute Solutions.**
BURNETT, M. G. *Anal. Chem.*, Vol. 35, No. 11, 1963, 1567-1570.
Details given of the cell used.
- (17) **The Determination of Oxygen in Vacuum Melted Steels, Molybdenum and Single Crystal Silica by Vacuum Fusion.**
DONOVAN, P. D. *et al. Analyst*, Vol. 88, October, 1963, 771-781.
Details given of vacuum fusion apparatus.
- (18) **A Versatile System for Liquid—Phase Quantum Yield Measurements.**
TRECKER, D. J. & HENRY, J. P. *Anal. Chem.*, Vol. 35, No. 12, 1963, 1882-1884.
Details of apparatus given.
- (19) **The Rapid Micro-determination of Carbon and Hydrogen with Magnesium Oxide—Catalyst Oxide Mixture.**
KAKABADSE, G. J. & MANOHIN, B. *Analyst*, Vol. 88, October, 1963, 816-818.
Details of combustion train.
- (20) **The Quantitative Determination of Active Hydrogen by a Modification of the Zerewitinoff Method.**
LEES, J. F. & LOBECK, R. T. *Analyst*, Vol. 88, October, 1963, 782-790.
Details of apparatus given.
- (21) **A Continuous Electrolytic Analyzer for Acidic or Basic Components of Process Gas Streams.**
BURNETT, R. L. & KLAVER, R. F. *Anal. Chem.*, Vol. 35, No. 11, 1963, 1709-1712.
Circuit diagram and details of the titration vessel given.

- (22) **A Rapid Radiochemical Procedure for Tin.**
GREENDALE, A. E. & LOVE, D. L. *Anal. Chem.*, Vol. 35, No. 11, 1963, 1712-1715.
Details of apparatus given.
- (23) **Method and Apparatus for Determination of Small Isotopic Oxygen Variations in Beryllium Oxide.**
MEYER, R. A. *et al. Anal. Chem.*, Vol. 35, No. 13, 1963, 2144-2146.

APPARATUS—PHYSICS

- (24) **A Combination Recording Sorption Balance and Extensometer.**
ROPER, H. & BRYDEN, J. G. *J. Sci. Instrum.*, Vol. 41, No. 2, 1964, 84-87.
Description of electronically controlled sorption balance and extensometer is given for use in the investigation of porous materials.
- (25) **A Calorimeter and Cryostat for measuring heats of Physical Adsorption.**
KINGTON, G. L., SMITH, P. S. *J. Sci. Instrum.*, Vol. 41, No. 3, 1964, 145-148.
Gives details of construction and method of use.
- (26) **Improved Recording Vacuum Balance.**
HARRIS, M. R. *J. Sci. Instrum.*, Vol. 41, No. 3, 1964, 163-166.
Describes the construction, calibration and use.
- (27) **A Simple Method for filling Manometers with Mercury.**
KAMPHAUSEN, H. A. *Lab. Pract.*, Vol. 13, No. 4, 1964, 326.
Method given.
- (28) **A simple Laboratory device for Winding Fused Quartz Springs and an Improved Design of Spring for Use in Sorption Balances.**
HAWKINS, C. T. & MUSTY, J. W. G. *J. Sci. Instrum.*, Vol. 40, No. 11, 1963, 544-545.
Method given for winding springs with reproducible characteristics, spring has a fibre through the centre giving much easier method of reading.

BALANCES

See 24, 26, 28.

BRAZING

- (29) **Brazing in Hydrogen by a Glow Discharge Method.**
BRANDT, B. *J. Sci. Instrum.*, Vol. 40, No. 11, 1963, 542.
Gives details for brazing metal parts in hydrogen safely without furnace or induction heater using glass vacuum chamber.

CELLS

- (30) **Controlled Potential Coulometry of Metals in Fused Lithium Chloride—Potassium Chloride Eutectic.**
CATON, R. D., FRUEND, H. *Anal. Chem.*, Vol. 36, No. 1, 1964, 15-19.
Details of fused salt cell assembly given.
- (31) **Three Compartment Cell for Polarography and Coulometry.**
COSTA, J. M. *et al. Anal. Chem.*, Vol. 36, No. 3, 1964, 698-699.
Details of cell construction given.

- (32) **Hydrogen Cell Assembly for Standard Electromotive Force Measurements.**
SIBBALD, P. G. & MATSUYAMA, G. *Anal. Chem.*, Vol. 35, No. 11, 1963, 1718-1721.
Details of hydrogen cell assembly given.
- (33) **Polarography of Lanthanum (III), Praseodymium (III), and Ytterbium (III), in Anhydrous Ethylenediamine.**
HALL, L. C. & FLANIGAN, D. A. *Anal. Chem.*, Vol. 35, No. 13, 1963, 2108-2112.
Problems are discussed and details given for the construction of the Polarographic Cell (see also 16).

CERAMICS

- (34) **Ceramic Material Heat-Treated by Gas.**
Engineering, Vol. 197, 31st January, 1964, 200.
Gives brief details of production of "Vycor" by Q.V.F.

CHROMATOGRAPHY

- (35) **A Reliable Chromatographic Column Support Using Porous Teflon.**
YANKEELOV, J. A. *Analytical Biochem.*, Vol. 7, No. 3, 1964, 342-344.
To counteract the affinity of glass surfaces for proteins a porous Teflon disc is used in place of the conventional sintered glass disc. To obtain a good fit the disc is cut oversize and rotated against the tube through the plane of the disc. When size is obtained the disc is pushed into tube to rest on preformed glass platform. The disc has shown no clogging over two years (see also 1, 2, 4, 14, 15, 16).

COMBUSTION PIPETTES

See 7.

CRYOSTATS

- (36) **A Cryogenic Liquid Level Detector Employing Thermistors.**
LEWIN, J. D. *J. Sci. Instrum.*, Vol. 40, No. 11, 1963, 539-540.
Discusses advantages and disadvantages of several types of detectors, gives circuit diagram for thermistor detector (see also 25).

ELECTRODES

- (37) **The Tubular Platinum Electrode.**
BLAEDEL, W. J. *et al. Anal. Chem.*, Vol. 35, No. 13, 1963, 2100-2103.
Discusses the theory and applications of the T.P.E. and gives details of construction (see also 49).

GAS ANALYSIS

See 7.

GAS GENERATORS

See 12.

GAUGES

- (38) **Liquid Nitrogen Gauge.**
TRUJELLO, S. M. & MARINO, L. L. *J. Sci. Instrum.*, Vol. 41, No. 3, 1964, 184.
Describes the construction of gauge to measure the liquid nitrogen in 100L Dewar Flasks.

(39) The Elimination of Resistance Films in Hot Cathode Ionisation Gauges.

de CSERNATONY, L. *J. Sci. Instrum.*, Vol. 40, No. 10, 1963, 504.

Gives details of the type of films which form and alter the resistance between the ion collector and the other electrodes. Methods of removal are given.

GLASS—CHEMICAL ANALYSIS

(40) Coulometric Titration of Total Arsenic and Arsenic (III) in Glasses.

WISE, W. M. & WILLIAMS, J. P. *Anal. Chem.*, Vol. 36, No. 1, 1964, 19-21.

Method given.

GLASS—PHYSICS

(41) Conference on the Physics of Optical Glass, Latham, Lancs, October, 1963.

COOK, G. H. *J. Sci. Instrum.*, Vol. 41, No. 2, 1964, 66-67.

Short account of the conference, with reviews of papers.

MANOMETERS

See 27.

MASS SPECTROMETRY

(42) A Gallium-Glass Heated Inlet Valve for Mass Spectrometry.

LEWIS, C. P. & HOBERECHT, H. D. *Anal. Chem.*, Vol. 35, No. 12, 1963, 1991.

Details of valve given.

POLAROGRAPHY

See 31, 33.

P.T.F.E.

(43) Preparation and application of a Perfluorocarbon Vacuum Sealant.

WELLMAN, C. R. *Anal. Chem.*, Vol. 36, No. 3, 1964, 697-698.

Details given for making, sealing or gasketing material from powdered Teflon (see also 35).

SAMPLING—LIQUIDS

See 13.

SEALS

(44) Method for Making Multiple Glass-Tungsten Rod Seals.

KAMPHAUSEN, H. A. *J. Sci. Instrum.*, Vol. 40, No. 12, 1963, 605.

Details of jig and technique used (see also 43, 49).

SILICA-WORKING

(45) A Method of Sealing Evacuated Wide Bore Silica Tubing.

HILL, D. E. & KING, G. D. *J. Sci. Instrum.*, Vol. 41, No. 3, 1964, 187-188.

Gives details of method (see also 28).

NOTE: *More abstractors are needed urgently—offers of help, quoting your field of science, to the Editors.*

BURNERS AND FLAME TECHNOLOGY

Report on a lecture given to North-Eastern Section on 20th March, 1964
by Mr. R. Cescotti, of W.S.A. Engineering Company

ON 20th March, 1964, at Leeds University Chemistry Department, Guy Fawkes came to Leeds in the form of Mr. R. Cescotti, of W.S.A. Engineering Company! During the evening, detonations of ear-splitting magnitude rent the air in lecture theatre "D"; this illustrated the power of the fuel explosions and we all sat forward in our chairs to learn about fuel mixtures and burners. This outstanding lecture was entitled "Burners and Flame Technology" and, in all seriousness, was one of the finest lectures I have attended, due to the careful preparation and thought given to it by Mr. Cescotti, who previously gave this lecture to a group of Glass Technologists in London.

The lecture started with flame speed demonstrations, these were done in one-inch glass tubes in the upright position, protected by Perspex safety tubes. Double injector systems with needle-valves were connected to the bases of the tubes and, first, Mr. Cescotti described the flame speed characteristics of the gases, using a black-board and gave us the reasons for the gases not burning down into the burner nozzle, which was mainly due to quenching action. He then showed us that heated barrels create "flash-back," and, returning to the upright glass tubes, showed the effect of different sizes of glass-tubing on the speed that the flame burned back down the tube as follows:—

We were shown that flashback could be accelerated when the nozzle was heated.

Repeat tests were made on oxygenated mixtures:—

- $\frac{1}{2}$ IN. TUBE
- (1) Air/coal gas . . . *Slow*
 - (2) Air/propane . . . *Very slow*
 - (3) Air/hydrogen . . . *Fast*

Then he showed the effect of a $\frac{5}{16}$ in. :—

- $\frac{5}{16}$ IN. TUBE
- (4) Air/coal gas . . . *Very slow*
 - (5) Air/propane . . . *Quenching occurred*
 - (6) Air/hydrogen . . . *Quite fast*
- in case (4) $\frac{5}{8}$ in. Coal gas/air (*Slow*).

- $\frac{5}{16}$ IN. TUBE
- (7) Coal gas/oxygen . . . *Rapid flashback*
 - (8) Propane/oxygen . . . *Quite rapid and noisy flashback*
 - (9) Hydrogen/oxygen . . . *Violent flashback*

Next we were shown the effect of using $\frac{1}{16}$ in. tubing and went on to some of the problems of burner design and the fuels used. Mr. Cescotti showed that both propane/oxygen and coal gas/oxygen can easily shear away from the nozzle, and that hydrogen/oxygen was more difficult to shear due to its demonstrated higher flame speed. The use of pilot tubes to anchor the flame to the burner head was illustrated.

We were then shown three burner heads fitted onto his testing manifold. These were Marshal Burners using (a) gas/air mixtures; (b) hydrogen/no air and (c) propane/oxygen; and we were able to study the flame effect of these mixtures. We were shown that, for propane, by using large pilotage areas flame anchorage is made possible by using packed chambers to slow the gas down.

Needle-valves were shown, using large diagrams to illustrate the two-angle needle taper for superfine control, with a first angle of 40° to shut off and a second angle of 6° to regulate.

This was followed by a demonstration of piloted flame control. A tubular burner was shown, half of which was modified with a low velocity gas curtain to anchor the flame. Mixture throughput speed was increased and the untreated half of the burner went out whilst the piloted portion remained stable. The gas used was changed to propane, a large sooty flame was produced and the conclusion was that propane requires a piloted flame, even when relatively low velocity flames are used.

Flame checks were shown, made from corrugated ribbon looped onto rod and tightly wound into a tube; this was followed by a demonstration with a 3ft. length of transparent plastic tubing connected through a flash arrester to another 3ft. length of transparent plastic tubing. It was of great interest to see that, when a gas/air mixture ignited, it passed slowly through the first tube but stopped at the flashback arrester, but, when a gas/oxygen mixture was ignited, it was seen to travel at high speed through the flash arrester, into the second transparent plastic tube, right back to the injector mixer, showing that flash arresters are not feasible with oxygen mixtures.

The final experiment was to illustrate the different flame transfer characteristics of the different fuels. A piece of silica tubing, about 20 mm. O.D. with a 2 to 3 mm. wall thickness, was selected. A needle-pointed flame was directed onto the tube with the intention of cutting a hole and measuring the time taken to cut through, listed below are the times taken :—

- (1) Oxygen/coal gas . No effect after 40 secs.
- (2) Oxygen/hydrogen Cut through after 18 secs.
- (3) Oxygen/propane. No effect after 40 secs.
- (4) Oxygen/hydrogen/propane Cut through in 6 secs.

A very fine injector system was shown for the mixing of the gases using the venturi

principles and an injector/double valve assembly was shown with a novel clamping action onto lin. gas piping.

The lecture was concluded with a question time and the North-Eastern Section would like to thank Mr. R. Cescotti for his generosity in giving up his very precious time, and also for incurring so much expense on our behalf.

At the end of the lecture Mr. Cescotti insisted on paying acknowledgment to the members of the Society who had organised the meeting and strongly urged that this spirit was emulated throughout—with wishes that the Society should go from strength to strength.

R. G. EUSTANCE

QUESTIONS AND ANSWERS

To date two queries have been received relating to articles which appeared in our first issue

Silica/Tungsten seals

Q. Why is it necessary to clean the tungsten prior to making the seal, as the flame conditions are such as to prevent oxide remaining?—Mr. Price.

A. Mr. Redford has replied that—there may be other types of surface contamination (e.g., Na salts) which, on heating, react with the tungsten, giving patchy seals.

Mullite

Q. What is Mullite?—Mr. Butler.

A. Messrs. Morgan Refractories, Wirral, Cheshire, have kindly supplied Mr. Porter with the following information—

Mullite ($3Al_2O_3 \cdot 2SiO_2$) is the most thermally stable alumina silicate, so called because it was first noted in the Isle of Mull. However, it occurs very little as a natural mineral and most Mullite that is incorporated into refractory products is made synthetically, either by manufactured Mullite grog being incorporated into the mixing, or by forming Mullite *in situ* from alumina silicate materials in the initial firing of the product. All alumina silicate mixtures and minerals on firing above $1,100^\circ C$ will produce a certain percentage of Mullite. Mullite is characterised by good load-bearing properties at high temperatures and good resistance to failure by thermal fluctuations and cycling.

Typical chemical analysis and physical properties of Triangle Impervious Mullite, number 671, are as follows:

Al_2O_3	58.9%
SiO_2	37.3%
Fe_2O_3	0.8%
TiO_2	0.1%
CaO	0.2%
MgO	0.1%
Na_2O	0.3%
K_2O	1.1%
Specific gravity	3.16
Bulk density	2.74 g. per c.c.
Apparent porosity	0.2%
Mean coefficient of linear expansion	5.8×10^{-5}
Bend strength at room temperature	13×10^3 lb. per sq. in.
Thermal conductivity	~ 25 BTU/ft. ² /in./°F
Maximum service temperature	$1,700^\circ C$

Bristol Symposium 1964

18th September

commencing 10.30 a.m.

Subject : Silica

Talks and demonstrations by courtesy of Thermal Syndicate Ltd.

REPORTS FROM THE SECTIONS

North-Eastern Section

Lecture entitled "Glass Technology and the Lampworker."

On 31st January, 1964, the North-Eastern Section were honoured by a visit from Professor Douglas, D.Sc., F.Inst.P., F.S.G.T., of Sheffield University. The lecture was preceded by a small dinner-party at which Professor Douglas, Professor Irving Head, of the Chemistry Department of Leeds University, a lecturer from the School of Ceramics, Leeds University, attended, as well as various members of our committee. This was held in Leeds University.

Professor Douglas started by describing the composition of the various types of glass, such as that used by window and bottle manufacturing companies. We were shown slides of large melting tanks and of various forming processes used in the glass industry. The bottle-making machine, in turret form, was extremely interesting and the slides of hand-drawn tubing were extremely enlightening. At this point, Professor Douglas demonstrated the methods of calculating stress and strain in the glass and illustrated the fantastic compression strength of the material. He also showed various testing techniques.

Professor Douglas illustrated with graphs the effect of adding various oxides which affected the coefficient of expansion and, also, the extension of the plastic state for forming glassware and the effect of its chemical durability.

We were then shown the effect of treatment on the surface of the glass. A rod had been immersed in acid and the surface coated with wax. The strength of the 7 mm. rod was fantastic—Professor Douglas failed to break it in half whilst wearing safety gloves. A toughened glass beer-bottle was demonstrated and, when a ball-bearing was dropped into it, a most dramatic shattering effect followed. The viscosity of molten glass was shown by using a falling-sphere-type viscometer.

After the extremely interesting lecture and demonstrations, Professor Douglas concluded with a promise that he would be happy to give a lecture to our Section at Sheffield University on the subject of reading strain patterns in glass using a strain viewer.

We would like to extend our warmest gratitude to Professor Douglas for travelling to Leeds and for giving up his time on our behalf.

Lecture given at Billingham Technical College by Mr. Sedgewick, Industrial Development Officer of J. Jobling & Co. Ltd., on 6th March, 1964.

Before the lecture Mr. Sedgewick was entertained by I.C.I. Ltd., Billingham Division.

He started the evening with a film entitled "Looking into Glass." This was extremely well compiled and showed the true craftsmen at work, as well as illustrating the many fine products and techniques of this leading glass company.

Mr. Sedgewick then followed the film with a most interesting lecture on the various aspects of borosilicate glass and the need for high chemical purity in the glass apparatus. This was illustrated by a most amusing story about a lead content which found its way in, due to the mixing of the glass cullet contaminated with lead colouring glass used for decorative ware, and the highly accurate modern analytical equipment which detected it in some evaporating basins used by a firm intent on finding a lead content in its chemicals.

Next, a fine technical film by Corning Glass Company was shown. This thrilled most of the people present with the bold advances made in glass technology and the terrific library of glass formulae at the Corning Research Centre.

Mr. Sedgewick followed up with a discussion and questions; this developed into quite a heated criss-cross of words as experienced glassblowers asked about tolerances, bow in tubing and optical qualities. These were all dealt with extremely well by Mr. Sedgewick and his two most able assistants.

The people who travelled from the Leeds area felt that the evening was true value indeed, and well worth the effort of braving the sleet and snow.

Our thanks are extended to Mr. Sedgewick and Billingham Technical College for giving us such an interesting lecture. R. EUSTANCE

Western Section

Meeting held on 27th January, 1964, at the Chemistry Glass Shop, University of Bristol "Deposition of metal films on glass"

This meeting was conducted as a composite of contributions by several members. Mr. D. W. Smith reviewed the method of depositing silver and copper chemically, concentrating mainly on the Brashear process and explaining in detail the making up of the solutions and the standard of cleaning needed. He followed with a successful practical demonstration of the method.

Outlines of the requirements and capabilities of vacuum deposition of metals were given by Mr. J. H. Burrow, who demonstrated the process by evaporating silver from a filament in an evacuated bulb. The bulb was later broken up to check the adherence of the metal, which is controlled by whether the metal easily oxidises.

A further type of metal deposition was described by Mr. Porter: colloidal suspensions and solutions in ores of metals, such as silver, platinum and gold, are painted onto a glass surface; slow heating dries the paint, then charring takes place and, finally, firing near the annealing point leaves a bright metal deposit.

The final demonstration of the evening was the deposition of stannic oxide on glass to form a conducting coating. Air was passed over heated stannic chloride and the smoke directed into a flask, heated to about 400°C, where a film deposited. The flask was broken for members to examine the film and check its low electrical resistance.

The main discussion on these processes centred around chemical silvering and of diagnosing causes of failure. It was agreed that the state of the glass surface is the most important factor and the best results are obtained when the silvering is done immediately after annealing and without any cleaning which can, if the wrong reagents are used, be the cause of difficulties. The session was very useful to members who had contact with these problems.

Meeting held on 24th February, 1964, at the Chemistry Department, University of Bristol "Dewar Construction"

Mr. J. H. Burrow opened by giving a description of the procedure adopted in making the ordinary "ring" seal, emphasising that the important factor was the correct internal contour of the seal, which should have no irregularities or crevice, usually the result of insufficient heat while joining.

The speaker gave the view that, with correct heating and control of rotation speed, blowing of the seal was unnecessary. Some glasses respond much easier than others, the old Hysil and Phoenix being excellent for making non-blown seals. The modern English Pyrex is also satisfactory if given extra heat.

Methods of support of the inner parts were then reviewed. On small sizes a simple iron tube with sufficient asbestos paper packing to fit the flared inner is the simplest way, and for the larger sizes a set of cranked extension jaws, which can be easily attached to the holding chuck.

Other methods include packing the inner within the outer by copper wire or corrugated strip, which can be dissolved out later.

Sometimes, after annealing, the heavy layer of oxide does not respond to nitric acid in which case the addition of hydrochloric acid helps.

Interspatial packing with asbestos string or tape is to be avoided if possible, though some commercial Dewars do contain three small spacing pads.

It was agreed that, when silvering has to follow manufacture, there should be a minimum of chemical treatment and powerful cleaning agents such as chromic acid should definitely be avoided.

A short description was then given of the construction of double "tailed" Dewars for liquid helium, showing how the necessary precision is achieved.

Mr. Porter of the Chemistry Department then proceeded to give practical demonstrations of the making of spherical Dewars from Pyrex flasks by cutting the outer, making a temporary taped join, with the inner supported in position, to allow the ring seal to be made and, finally, after removal of packing, the two outer halves were rejoined.

The attention of members was drawn to an interesting failure where, during the making of the ring seal, the outer had shattered due to the explosion of a trapped gas mixture—an unusual circumstance, to be avoided by flushing with air before actually sealing.

Much entertainment was derived from Mr. Burrow's efforts to make the final seal when working with unfamiliar burners—he called for more gas and was supplied with propane. This did not suit the large ring-burner, resulting in much backfiring and the depositing of soot over the operator and bystanders.

North-Western Section

Meeting held at Warrington Technical College on Friday, 20th March, 1964.

Twenty-four members attended this meeting where a lecture and film-show were given by Mr. H. Cole, M.A., F.R.I.C., F.Inst.P., F.S.G.T., entitled "What is Glass?" The lecture, giving basic introductions to glass manufacture and applications, was well presented and was followed by many questions. Thanks are due to the lecturer and to Mr. K. Knocton, of Pilkington Brothers' Photographic Department, for his assistance in projection of the film.

Southern Section

Meeting held in the Main Lecture Theatre, Queen Elizabeth College, on Wednesday, 15th January, 1964.

During his talk on the "Nature and Properties of Silica," Mr. T. P. Browell, of Thermal Syndicate Ltd., described, in great detail, the various types of silica, he also explained the methods used to fuse the raw materials into tubes and complex shapes. The optical properties of silica were also described, and the speaker was able to demonstrate how copper, deposited from a diamond cutting wheel, altered the optical properties of silica. At the end of the talk members had many questions to ask and the meeting closed with all present having a greater understanding of the problems of working with silica.

The Southern Section stag dinner was held on 14th February, 1964, at the Horse Shoe Hotel, Tottenham Court Road, the object being to enable members to meet socially and get to know one another. From the number of friends who greeted one another, and the many introductions made, the evening could be considered a success.

It was interesting to note the many members and visitors who were either directors, partners or representatives of companies who supply glassblowers' requirements, joining their glassblower friends in a social evening.

Committee member F. A. J. Luadaka, who is in hospital, was unable to join us and we therefore wish him a speedy recovery.

Future meetings of the Southern Section

Wednesday, 15th April, 1964, at 7 p.m. in the Main Lecture Theatre, Chemistry Department, Queen Elizabeth College, Campden Hill Road, London, W.8: "Annealing Furnaces" by R. W. A. Royce, Esq., A.E.W. Ltd.

Twenty-two members attended a visit to the works of Messrs. Quickfit and Quartz at Stone on 10th March.

In the future Dr. R. E. Bastik, of Chance Bros. Ltd., Smethwick, has agreed to lecture on Veredia Glass Tubing and a rota system has been devised for attendance at Council meetings—five members having offered their services.

The educational policy of the Society will be discussed at a meeting on 24th April, and reported later.

P. ATKINSON

Midland Section

A general meeting was held on the 20th March, 1964, at Messrs. Courtaulds. The number of members that attended this meeting was indeed gratifying and the discussion that followed gave the committee an impression of what members expected from the Society. A full report of this was made in the Midland Section News Report produced by Mr. Bert Cale.

The visit made to Quickfit and Quartz on the 15th April also attracted a large number of people, who gathered at 2.15 p.m. in the canteen at the entrance to the works. Here the party divided up into small groups and set off with their guides to tour the factory. One would think that taking glassblowers to Quickfit and Quartz would be rather like taking coals to Newcastle but, judging by the barrage of questions and the difficulty the guides had in moving their groups from one section to another, great interest was shown.

Members seemed very pleased and satisfied with the visit, and most people were surprised to see the extent to which Quickfit and Quartz have mechanised their production of glassware.

A general meeting was arranged to follow the Quickfit and Quartz visit at the Three Crowns Inn, Stone. This was requested by members at the previous meeting at Courtaulds Ltd., but so few people stayed to attend that it had to be called off.

Mr. Bill Blower arranged a visit to Cadbury Brothers at Bournville on the 14th May, 1964.

WORKSHOP NOTES

CUTTING MACHINE FOR REFRACTORY TUBES

IN order to obtain improved accuracy in the cutting of silica and alumina tubes, a machine was designed to operate in conjunction with an ordinary glass lathe. It is a versatile tool, cutting accurately squared edges, which can be faced to a smooth finish without altering the lathe setting. It can be used to cut along the axis, or to make a number of slots in definite positions around the circumference of the tube. It can also be used for glass tubes when great accuracy is required.

A 5in. diameter x 1mm. diamond-impregnated wheel is used for cutting, and a 3in. diameter diamond cup wheel for facing. The wheels are mounted adjacent to each other on the same shaft. A Desoutter high-speed pneumatic drill, with suitably arborred shaft provides the drive. The motor is held by a bracket, which is itself held by a smooth-surfaced pipe, set in a flat plate which rests on the lathe traverse platform. It was found to be unnecessary to clamp this, the weight of the machine being sufficient to prevent vibration.

Holes and spigots position the machine on the platform. The bracket is adjustable for height and rotation on the pipe, and a worm-gear feed is incorporated on the bracket.

The wheels are water-cooled, the cooling jets being attached to a semi-circular guard fitted over the wheels. The waste water and mist are contained by a thin transparent plastic sleeve which envelopes completely the motor and work. The ends of the sleeve are led down to a tray which collects the water and channels it to a drain.

For parting a tube, the tube is held in the lathe chucks and rotated by the lathe motor, the direction of rotation being against the direction of the wheel: the wheel is fed downwards into the tube by means of a hand-wheel on the worm gear. For facing a tube, the cup wheel is located horizontally with the edge of the tube, and pressed against it by moving the lathe traverse. For axis cuts the cutting wheel is used in conjunction with the lathe traverse. When the machine has been used, it is easily removed from the platform by lifting out of the spigot holes, all the flexible feeds being still attached.

J. CONABOY
Royal Radar Establishment
Malvern, Worcs.

CARBON LATHE TOOLS

Most commercially available carbon lathe tools, whilst being composed of the correct grade of carbon (EY9), suffer from the same complaint as many "home-made" ones, shaky and difficult to replace handles. The glassblower often needs an oddly shaped paddle at short notice or he may break an existing one. Most glassblowers prefer to make their own tools at all times. The following note indicates a strong and reliable method of attaching the handle to the carbon paddle.

The carbon is drilled along its width and plugged with a length of brass rod. A plate of $\frac{1}{8}$ in. mild steel is cut to the shape of the end of the carbon and holes are drilled a short distance from each end. The carbon is marked beneath these holes and holes are drilled down through the carbon and the brass. The brass is tapped to a suitable B.A. size. A length of $\frac{1}{8}$ in. or $\frac{3}{16}$ in. diameter mild steel rod is welded to the centre of the plate to form the handle.

D. W. SMITH
Imperial Tobacco Co. (of G.B. & I.) Ltd.
Research Department
Bristol, 3

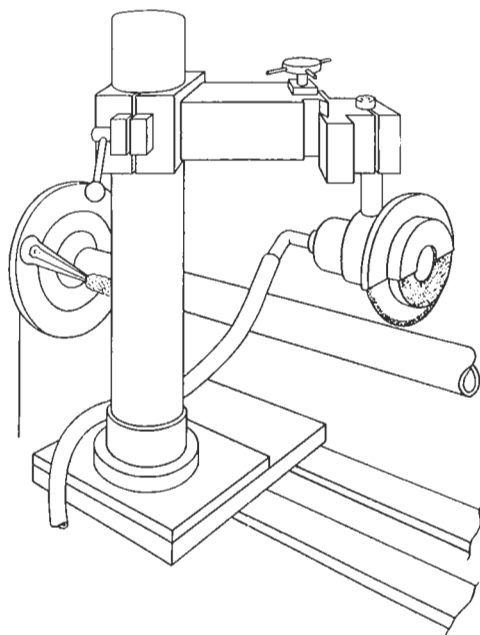

ADDITIONS TO LIST OF MEMBERS

Full Members

<i>Name</i>	<i>Business Address</i>	<i>Home Address</i>
Bowyer, S. ...	Petrochemicals Ltd., Carrington, Urmston, Lancs	20 Sylvan Avenue, Sale, Cheshire
Brown, I. J. ...	Welsh School of Pharmacy, Cathays Park, Cardiff	37 Cyntwell Crescent, Ely, Cardiff, Glamorgan
Bullock, K. G. ...	Petrochemicals Ltd., Carrington, Urmston, Cheshire	15 Daniel Admason Avenue, Partington, Cheshire
Cookson, J. W. ...	Courtaulds Ltd., Coventry ...	19 Park View Road, Birmingham, 31
Eisenberg, A. ...	Esso Research Ltd., Abingdon, Berks	52 Whitehorns Way, Drayton, Abingdon, Berks
Eisenberg, J. ...	Organic Chemistry Department, Liverpool University	11 Barnet Street, St. Helens, Lancs
Gettings, R. S. ...	Shell Chemicals Ltd., Urmston, Lancs	16 Booth Drive, Davyhulme, Urmston, Lancs
Hilditch, A. A. ...	Thornton Research Centre, Ellesmere Port, Cheshire	121 Robinhood Lane, Helsby, Warrington, Lancs
Hopkins, D. J. ...	Chemistry Department, University of Leicester	31 Denmead Avenue, Wigston Fields, Leicester
Hutson, P. ...	Chemistry Department, College of Science and Technology, Manchester	23 Mount Pleasant, Simister, Prestwich, Lancs
James, M. ...	I.C.I. Ltd., Billingham ...	7 Kirkham Row, Beechwood, Middlesbrough
McMillan, W. R. ...	I.C.I. Ltd., Grangemouth, Stirlingshire, N.B.	50 Wallace Street, Grangemouth, Stirlingshire
Mears, E. ...	Thornton Research Centre, Chester ...	122 Hartford Road, Davenham, Northwich, Cheshire
Meek, D. E. ...	I.C.I. Ltd., Plastics Division, Welwyn Garden City, Herts	
Milner, J. ...	Thornton Research Centre, Chester ...	29 Melling Road, Wallasey, Cheshire
Morgan, R. H. ...	Admiralty Oil Laboratory, Gt. West Road, Brentwood, Middx	
Morrison, H. R. ...	Roche Products Ltd., Welwyn Garden City, Herts	27 Newfields, Welwyn Garden City, Herts
Osborne, A. J. ...	U.K.A.E.A., Aldermaston, Berks ...	3 Deanswood Road, Tadley, Hants
Payne, N. ...	I.C.I. Ltd., Plastics Division, Welwyn Garden City, Herts	
Perry, A. R. ...	War Department, Porton, Salisbury, Wilts	
Piesse, J. A. J. ...	Borax Consolidated Ltd., Chessington, Surrey	66 Laggan Road, Maidenhead, Berks
Pike, K. G. ...	Chemistry Department, University of Sussex	83 Lincoln Avenue, Peacehaven, Sussex
Pilley, L. J. ...	Courtaulds Ltd., Coventry ...	30 Mary Herbert Street, Cheylesmore, Coventry
Preston, J. L. ...	Chemistry Department, Imperial College, London, S.W.7	239 Southbury Road, Enfield, Middx
Richter, W. A. ...	Quickfit & Quartz Ltd., Stone, Staffs	41 Berry Road, Tillington, Stafford
Roberts, E. G. ...	Chemistry Department, University College, London, W.C.1	121 Northumberland Road, Welling, Kent
Sanderson, D. A. ...	Aimer Products Ltd., Rochester Place, London, N.W.1	
Saxton, D. G. ...	Clarendon Laboratory, Oxford ...	49 Mayfair Road, Cowley, Oxford
Schofield, E. ...	Chemical Engineering Department, University of Leeds	40 Kentmere Approach, Leeds, 14

<i>Name</i>	<i>Business Address</i>	<i>Home Address</i>
Thomson, A. G. ...	U.K.A.E.A., Aldermaston, Berks ...	36 Oliver Drive, Calcot, Reading, Berks
White, R. B. ...	Marconi Co. Ltd., Gt. Baddow, Essex	16 Heycroft Way, Tiptree, Essex
Watking, R. ...	Ministry of Aviation, Waltham Abbey, Essex	45 Watersmeet, Great Parndon, Harlow, Essex
Wingate, J. ...	Chemical Inspectorate, Royal Arsenal, S.E.18	74 Wightman Road, London, N.4
Zamit, I. G. ...	Anchor Glass Co. Ltd., North Circular Road, N.W.2	

Student Members

Bancroft, D. H. ...	I.C.I. Ltd., Fibres Division, Harrogate, Yorks	98 Main Street, Burley-in-Warfedale, Ilkley, Yorks
Cross, P. G. ...	20th Century Electronics Ltd., New Addington, Surrey	57 King Henry's Drive, New Addington, Surrey
Martin, J. ...	National Smelting Co. Ltd., Avonmouth	"Swissdene," Wolton Road, Clevedon, Somerset
Richards, J. ...	Clarendon Laboratory, Oxford ...	"Catkins," Tilgarsley Road, Eynsham, Oxon
Robertshaw, G. ...	I.C.I. Ltd., Fibres Division, Harrogate, Yorks	"Roselea," Arkendale, Knaresborough, Yorks
Seymour, A. R. J. ...	Scott, Bader & Co. Ltd., Wollaston, Northants	14 Earls Barton Road, Doddington, Wellingborough, Northants
Wizell, B. C. ...	Battersea C.A.T., London, S.W.11 ...	182 Wimbledon Park Road, London, S.W.18

Note : Ten Associate Members whose names will appear in the next issue of this Journal