

Journal of the British Society of Scientific Glassblowers

VOL. 1

SEPTEMBER, 1964

No. 3

EDITORIAL

THERE is no doubt that the first two issues of our Journal have been very well received and have set a standard with which subsequent issues will be compared.

It must be made clear, however, that in producing them, the Society's finances have been seriously depleted and considerable thought at editorial level had to take place before embarking on No. 3. But as a result of appeals by our advertising manager and a magnificent response by advertisers, who have agreed to increased rates before the contract period had ended, we should now be able to maintain the standard. **We trust that members of the Society will also respond with a continuous supply of suitable material for publication.**

With regard to training and qualification schemes, it is obvious that ultimately a solution

must be arrived at and it appears that as a result of discussions at various levels, misunderstanding exists which, by goodwill, must be overcome, enabling the responsible committee to submit a compromise proposal which will be acceptable to all.

We understand that our American colleagues have been engaged on a similar project for many years and have failed to reach a definite answer. No doubt they will be watching our efforts with interest, but in fact ours should be an easier task as certain problems such as distance and uniformity of approach are less acute.

Thus, by arriving at a solution we shall be helping glassblowers in all parts of the world to establish themselves as competent, qualified craftsmen. (*See page 46.*)

COUNCIL MEETING

A COUNCIL Meeting was held on Saturday, 4th July, 1964, at the Birmingham College of Advanced Technology, with Mr. S. G. Yorke as Chairman. Seventeen Councillors attended and apologies for absence were received from four others. The meeting, as usual, lasted the whole day, but one improvement from the Councillors' point of view was, that with experience, procedure has become rather more streamlined.

Officers' reports

The secretary reported that he had handled a further 47 applications for membership since the last meeting and our total membership was now 259, but some of these had not yet paid up. We have four overseas members and two more applicants. As ours is a learned society, if registered with the income tax authorities, it should be possible for our members to claim their subscriptions as expenses.

The treasurer made his report to Council, which was accepted. He was given authority to obtain a more convenient design of membership card for next year.

The P.R.O. reported that advance notices for the forthcoming symposium will appear in about five journals.

Section reports

All six sections sent in reports of meetings, works visits, lectures and committee meetings.

Rules

Mr. J. Price, chairman of the Rules Sub-Committee reported that he had sent out letters asking for comments on rules 1 to 5 but had not yet received all the replies, this was now an urgent matter.

Education

Five reports from sections had now been received and the chairman, who is also chairman of the Educational Sub-Committee would be collating these in order to present a full report to Council. As usual a great deal of discussion went on, the respective merits of various organisations, diplomas and certificates being extolled or decried.

The next Council meeting will be held in the same place on *Saturday, 3rd October, 1964.*

J. A. FROST

British Society of Scientific Glassblowers

Founded 1960

Chairman

S. G. YORKE

Grove House, Longton Road
Stone, Staffs

Hon. Treasurer

D. A. HENSON

3 Oliver Drive
Calcot, Reading

Hon. Secretary

I. C. P. SMITH

65 Woodberry Way
Chingford, London, E.4
SILverthorn 3295

SECTION ACTIVITIES

Midland Section

On the 25th June a General Meeting was held in the Engineering Centre, Birmingham. Several matters had to be resolved, not least the fact that our chairman, Mr. W. Blower, and treasurer, Mr. G. Hill had both resigned. Rules revision was also due to be discussed in order to make the Midland Section's comments known to the rules sub-committee. There was a good attendance and one new committee member, Mr. J. Cookson of Courtaulds was elected. Mr. D. Swan, already a committee member, was elected treasurer and the committee intend to elect a new chairman at their next meeting. As no one would take on the job of delegate to the rules sub-committee Mr. S. Yorke agreed to make notes on rules revision and pass these on to the sub-committee. Rules 1 to 5 were discussed with great animation and various recommendations were made. The meeting ended with a tour of

the Art Glass Exhibition currently on show at the Engineering Centre.

Our retiring chairman, Mr. W. A. Blower, has been glassblowing for many years, in the early days of Q & Q and latterly at Cadbury Bros., Bournville. He was a founder member of our Society and, from its earliest beginnings has always worked hard to further the interest of members. It is understood that he is also leaving the Society; his friends deplore this and can only thank him for his services to the Society in the past.

At the Council Meeting held in Birmingham on the 4th July, the Midland Section delegates were gratified to receive a vote of confidence from the meeting and are equally certain that this confidence will not be misplaced.

R. S. HANLEY

Thames Valley Section

Five meetings have been held since our last report. At the first the Western Section's aims were discussed and a motion passed complimenting them on their efforts, although we did not agree with certain items.

A new committee was formed at the second meeting comprising three members, namely: Chairman, J. Frost; Secretary, A. G. Thomson; and Treasurer, M. Priem. This number may be increased at a later date. Rules one to five were discussed and our comments passed on to the rules committee.

On 12th May Mr. Cesscotti delivered his now well known lecture on burners, a full report on which appeared under the North-Eastern Section reports in the last Journal.

Our last two meetings, 26th May and 2nd June, were held solely for the purpose of discussing and formulating our (TV) Education Policy, the major point being the need for an academic qualification as well as a manipulative one. The aim of the Society is to raise the status of the glassblower and to do this we must follow the example of other societies and organisations by having our own theoretical qualifications.

Considering that a least half of our members have to travel 30 miles to meetings we feel that our 60 to 70 per cent attendance is very good.

ALAN G. THOMSON
Secretary

Southern Section

A meeting was held in the main Chemistry Lecture Theatre, Queen Elizabeth College, on Wednesday, 15th April, 1964. The Southern Section were very fortunate to have Mr. Royce of A.E.W. Ltd., as guest speaker for this meeting. During his talk on "Annealing Ovens," the speaker, with the aid of slides and drawings, explained the principles and advantages of air circulating annealing ovens.

On Wednesday, 27th May, 1964, an open meeting was held in the main Chemistry Lecture Theatre, Queen Elizabeth College. The subject was "The Training and Education of Glassblowers." A panel of four speakers gave their views, the meeting was then declared open to enable members to express their own opinions on this important subject.

A party of 18 visited the works of Messrs. Fisons Scientific Apparatus Ltd., on Wednesday, 16th June, 1964, and were shown the extensive stocks of glassware and other items held at the works. After lunch the party was split into small groups and conducted around the glass-

blowing section, many questions were asked, and special demonstrations of apparatus not in production at the time were arranged. We thank Messrs. Fisons Ltd. for the hospitality extended to the Southern Section on this occasion and for an interesting, instructive and enjoyable day at Loughborough.

Dagenham Cables Sports Club held their Fete and Gala day on Saturday, 27th June, 1964, and Messrs. Evans, Gee, Smith, Wingate and White attended to demonstrate glassblowing. The demonstration, staged in a tent, attracted many interested spectators. Jock Wingate was much admired for his skill at making glass animals, I. C. P. Smith displayed a great talent for making glass pigs, Ken Gee obliged with a batch of splash heads and condensers and Ted Evans demonstrated a fine hundred yards sprint whilst drawing fine bore tubing. This was the first demonstration by the section and it was considered to be both worthwhile and enjoyable by all taking part.

E. WHITE

Western Section

Welding

On 27th April, 1964, Mr. C. Gibbs of the New Chemistry Department, University of Bristol, gave a talk with demonstrations on Argon Arc Welding.

The main topic was small scale mechanically jigged welding on stainless steel for ultra high vacuum use, the testing being carried out by a helium leak detector. The evening was concluded at the invitation of Mr. H. Banwell with an inspection of the engineering section of the department.

Annual Works Visit

On 25th May, 1964, members of the section journeyed to Stourbridge where two glass factories were inspected.

Most of the morning was occupied by a comprehensive tour of Messrs. Stuart and Sons, where all the processes involved in producing cut glass were shown. Cleaning and mixing the ingredients for glassmaking were followed by the melting process and the forming of various articles by glassblowers. Some time was spent in the cutting, polishing and finishing rooms, the tour ending at the exhibition department where members had the opportunity to purchase.

The second visit was to the glassworks of Messrs. Plowden and Thompson where Mr. Threlfall welcomed the party and arranged a tour of the works.

Here, besides glassmaking, the hand drawing of soda glass tube was being carried out, and mould blowing of Kodial cylinders. After showing a special process for fine bore tubing, the stockrooms containing many colours of neon sign tubing and special tungsten sealing glasses were inspected and samples were distributed.

We thank Mr. Threlfall for his hospitality and assistance in arranging the trip.

EDITORIAL NOTE. *A very comprehensive and entertaining report on these visits was submitted by Mr. F. Porter, but unfortunately was too long to publish.*

A Special General Meeting was held on 15th June to make final arrangements for the Symposium and discuss the Educational policy of the Society.

The report on education submitted to Council was discussed and it was pointed out that it was meant to be a basis for general consideration rather than a finalised proposal.

D. W. SMITH

North-Eastern Section

Metal Glass seals by R. G. Butler

At a meeting held on 24th April, 1964, at Billingham Technical College, Mr. H. Butler, Chief Glassblower at the Chemistry Department of Leeds University, lectured and demonstrated the art of sealing metal to glass.

The lecture began with a list of glasses suitable for sealing to various metals and the importance of matching the expansion coefficient of both materials through a temperature range.

It was shown that an oxide layer is essential for a seal: a rod of metal heated in an inert atmosphere and covered with glass will not make a good seal but with the correct oxide layer a seal is possible.

For the demonstration G.E.C. W.I. glass was used, sealing to tungsten.

The tungsten was centreless ground, 1mm. diameter and cleaned electrically in a solution of sodium nitrate using 10 v a.c. A new type of blowlamp was used which allowed a choice of pre-mix or cannon fire and this caused a great deal of interest amongst the glassblowers present.

The tungsten was carefully oxidised, sleeved and beaded ready for sealing in.

Then the making of a two lead pinch seal was demonstrated using a special jig for holding the wires.

Throughout, the precautions necessary for a sound, serviceable seal were given.

Then followed a description of the method of making copper glass seals including the cleaning, boring, treatment of the feather edge and the final colour of the seal.

Three Kovar sealing techniques were also described in detail.

There was great appreciation of those attending for the "live" demonstration and following the lecture the various types of seals were laid out for inspection.

Methods of producing a vacuum by R. S. Knight

At Leeds University on 10th June, Mr. R. S. Knight, of Leybold Elliott Ltd., gave a talk on methods of producing a vacuum.

He began by describing the ordinary mercury manometer with its Torricellian vacuum in the top, from which the Torr unit of measurement was derived.

The degrees of vacuum obtained were described in terms of this unit down to the ultra high vacuum range of 10^{-12} Torr and the importance of temperature on the movement of the residual gas molecules was pointed out.

Then various methods of producing vacuum were surveyed, beginning with the simple water pump which will produce 15 Torr and the steam ejector pump producing a pressure of better than 2 Torr.

Then followed the mechanical rotary pump, ballasted and unballasted, and also the high speed Roots pump which, in conjunction with the former, extends into the medium high vacuum range.

Diffusion pumps were next discussed. Firstly the glass mercury type which although of slow speeds with suitable trapping produces very high vacua. Secondly, oil pumps, traps and baffles were reviewed with diagrams of the inner jet assembly.

Other methods of pumping were also described such as getter, getter-ion, evapor-ion and finally cryogenic pumping by means of liquid helium. These last types give the ultra high vacuum pressures of 10^{-10} to 10^{-12} Torr.

Slides were shown illustrating types of pumping sets and auxiliary components and in the ones dealing with ultra high vacuum the importance of baking out was stressed and also the pumping action of ionisation gauges.

The lecturer closed by pointing out the many modern uses of vacuum equipment including high altitude simulation for space research.

We are very much indebted to Mr. Knight and to Leybold Elliott Ltd. for this very fine lecture and extensive exhibition of equipment.

Thanks are also extended to Mr. Flanigan for his assistance with the slide projector.

R. G. EUSTANCE

North-Western Section

Mr. J. Edkins has been appointed North-Western representative of the sub-committee dealing with rules and constitution. As requested, a committee meeting of the North-Western Section was held at the Warrington Technical College to discuss the rules, and amendments were offered. A list of these has been sent to Mr. S. Yorke.

A meeting and lecture was held in the Robinson Laboratory, Manchester University. A lecture given by Dr. R. E. Bastick, Development Manager, Chance Brothers, Birmingham, dealt with Veridia glass tubing and was attended by 20 members.

A works visit is fixed for Tuesday, 21st July, 1964, to Messrs. Plowden and Thompson, glass manufacturers, and also Messrs. Stuarts, crystal glass, kindly arranged by Mr. R. E. Threlfall, M.A., F.S.G.T., managing director of Plowdens. The maximum number allowed is 15 per party.

A lecture is to be given by Professor R. W. Douglas, D.Sc., F.Inst.P., F.S.G.T. to the North-Western Section, on 27th August, 1964, at 3.30 p.m., at the Pilkington Research Laboratories' Lecture Theatre, Lathom, Lancashire.

P. A. ATKINSON

UNIVERSITY OF ESSEX
DEPARTMENT OF CHEMISTRY

Vacancies exist in the Department of Chemistry for Senior Technicians (£810—£1,010), Technicians (£580—£815) and Junior Technicians (£280—£500) to assist in the management and organisation of the chemical laboratories.

One of the senior posts will be reserved for a competent glassblower and it is hoped that another of those appointed will have experience in electronics.

Applications should be sent to the Professor of Chemistry, University of Essex, Wivenhoe Park, Colchester, Essex.

CLASSIFIED ADVERTISEMENTS

SCIENTIFIC GLASSBLOWER required for research and development department of chemical manufacturers. Must have good all-round experience, also use of lathe. --Apply to Personnel Department, Laporte Chemicals Ltd., P.O. Box 8, Luton, Beds.

(Classified advertisements 6s. per line)

The Journal is published quarterly by the B.S.S.G. and is available free to members and at 5s. per copy (or 17s. 6d. per annum) to non-members. Editorial communications should be addressed to the Editors, c/o Departments of Physics and Chemistry, University of Bristol, and enquiries for advertising space to Mr. I. C. P. Smith, 65 Woodberry Way, Chingford, London, E.4. Printed in Great Britain by E. G. Ellis & Sons, Willow Street, London, E.4.

© B.S.S.G. and Contributors, 1964

EDITORIAL NOTE. *Should any case of non-receipt of the Journal or other Society notices become known to members please advise those affected to report the matter to one of the officials.*

WORKSHOP NOTES

RELEASING SEIZED STOPCOCKS AND GROUND GLASS JOINTS

Research Laboratories, Joseph Crossfield & Sons Ltd., 31st July, 1964

IN our experience of using stopcocks, seizure of the plug in the barrel occurs quite frequently, regardless of the care taken and grease used. This is due mainly to the excessive area of ground glass surfaces in contact with each other and the taper of 1 in 10 which in a stopcock (or joint) of this size is not great enough. When using glassware which contains ground glass joints, greasing of these members does not always ensure easy dismantling. On occasion, the nature of the materials being handled has a detrimental effect on the grease and seizure takes place. Over a period of years we have been freeing these sections by the following methods. The basic idea being to expand (or contract) one member at a greater rate than the other. This is achieved by either filling the inner member with a liquid (usually water) and heating the outer member with a hand torch. Generally, it is sufficient to use gas only, but a stubborn joint may require a soft oxy/gas flame.

For stopcocks the yoke is removed and water is introduced to the inside of the plug by cutting off the small pimple found at one end of the handle. This is done conveniently on a glass saw, but failing this it can be removed in the burner. In this case, care must be taken to ensure that the plug handle does not crack due to strain and when freed the plug should be annealed. It is not necessary to close the handle again, if left open it is ready in case of a further seizure.

When filled with liquid, the stopcock barrel is heated evenly over its surface for a period (best determined by experience). The stopcock is then gripped by the barrel (using asbestos gloves) and tapped by the base of the plug on a hard surface (e.g. a floor). A folded cloth or piece of wood on the floor will prevent the plug base from chipping. The plug should come out easily, but a badly seized stopcock may need a further

period of heating. It is not advisable to hold the stopcock by the side arms when tapping as this may cause them to snap off.

On occasion we have had to free a stopcock which was seized in the closed position and containing a volatile liquid in the plug bore. In this case, to avoid accidents, the plug can be filled with liquid nitrogen. Heating is unnecessary in this case, but it will be found that it is not as easy to fill the plug with liquid nitrogen and also it is not always readily available.

For ground glass joints the procedure is the same, but is simplified because there are usually several openings through which liquid can be introduced. After chosing the most suitable point to introduce water, the other openings are closed with rubber bungs, etc. Sufficient water to cover the joint is then added and the exterior of the joint heated with a small flame. Care must be taken to confine the heating to the joint only and hence giving the maximum expansion difference. Again, depending upon the joint, a soft oxy/gas flame may be necessary. It has been found by experience that this type of joint can usually be dismantled when the water inside the joints starts to boil. Gloves should be worn to prevent scalding the hands when the joint comes apart.

In our experience using these methods we have had two failures and these were tested to destruction and found to be cemented together and could not be chipped apart.

The above methods are suitable only for joints having a hollow centre. Should the joint have a solid inner member or be so designed that liquid could not be introduced into the inner member, then heating the outer member will cause the inner member to expand at the same rate due to their close contact.

J. STOCKTON

ABSTRACTS

BURNERS

(46) Burners and Flame Technology.

Cescotti, R., *J. Brit. Soc. Sci. Glassblowers*, Vol. 1, No. 2, 1964, 27-8.

Report on a lecture, discusses flames, burners and their characteristics.

CERAMICS. See 58, 74, 77, 82.

CHROMATOGRAPHY

(47) An Automatic Starter for Paper Chromatography.

Perold, G. W., *Analyst*, Vol. 89, 1964, 297-8.

Gives details of construction of the apparatus, a syphon is primed by means of an alarm clock mechanism.

DISTILLATION

(48) How to smooth out Boiling.

Barr, W. E., *Fusion*, Vol. 11, No. 2, 1964, 14.

Describes the technique of sealing glass particles on the inside of flasks to promote even boiling.

(49) Modification of the Semi-Micro Distillation Kjeldahl (Head) Apparatus.

Hanif, A. H., *Lab. Pract.*, Vol. 13, No. 6, 1964, 527.

Gives a very short account of a slight modification to the semi-micro distillation head, claims to give more reproducible results.

FLOWMETERS

(50) A Flowmeter for measuring very low rates of Helium Gas Flow.

Black, R. M., Rhodes, R. G., and Spicer, C. H., *J. Sci. Instrum.*, Vol. 41, No. 5, 1964, 345-6.

To attain a high degree of accuracy the pressure drop must not be greater than 4 mm. of water. This is achieved by the design described. It is essentially a soap film flowmeter with a sensitive manometer connected across it to measure the back pressure. See also 71.

GAS ANALYSIS

(51) A Simple, Rapid, Recording Carbon-Dioxide Analyser.

Austin, W. T. S., *Lancet*, November 9th, 1963, p.p. 984-5.

Describes the apparatus with drawings. Uses the differential gas pressure in a Wheatstone Bridge type of network.

(52) The measurement of Gas Evolution Rates.

Block, H., *J. Sci. Instrum.*, Vol. 41, No. 6, 1964, 370-2.

This paper describes two pieces of apparatus for measuring the rate of evolution of a soluble gas from reactants in solution. One being a constant pressure type, the other removes the gas as it is formed. Details of the apparatus are given along with control circuits.

GLASS—CHEMISTRY

(53) "Corex" Chemically Strengthened Pipettes, produced by Corning Glass Works. "Safe-Gard" Tempered Tipped Pipettes, produced by Owens-Illinois.

The Glass Industry, Vol. 44, No. 12, 1963, 692.

"Corex" pipettes are claimed to have outlasted standard pipettes by 6-1 in market and laboratory tests. The new product is made up of a special glass composition and treated by one of the "Chemcor" processes. "Safe-Gard" is the name given to an Owens-Illinois pipette which features a tempered tip and made from N-51A, a special borosilicate glass which minimizes fogging and resists abrasion.

(54) Importance of Lead in Glass.

Leisir, C. F., *The Glass Industry*, Vol. 44, No. 10, 1963, 574.

Discusses the effects of varying lead oxide content in glasses, on the mechanical, thermal, optical and other properties. See also 56.

(55) Cord Identification by X-ray Fluorescence.

Carr, R. E., Stonebarger, F. J., *The Glass Industry*, Vol. 44, No. 10, 1963, 557.

A brief description of this cord identification method, along with a discussion of a particular application of the analysis of cord in glass, by which useful information has been obtained. The method is based on a comparison of a sample containing cord with a sample of glass from the same object, free from cord.

(56) Glass Division Meeting for 1963, held at Bedford Springs, Bedford, Penna, U.S.A.

The Glass Industry, Vol. 44, No. 12, 1963, 672.

Brief reviews including sliding friction and related surface damage in glass-metal systems. The "creep" of glass at room temperature. Fracture and flaws in glass. Effect of silicone quenching and acid polishing on glass strength. Quality control applied to non-automatic production. Strengthening by ion-exchange.

(57) The Effect of Heat-Treatment on the Breaking Strength of Glass.

Brearley, W. and Holloway, D. G., *Phys. Chem. Glasses*, Vol. 4, No. 3, 1963, 69.

Groups of standard samples of soda-lime-silica glass were heat-treated to varying temperatures and the difference in breaking strength determined in torsion. The reduction or increase in strengths are indicated. Flaws which can originate the fracture are believed to be "surface inclusions" formed by the bonding of microscopic dirt particles to the surface.

(58) Thermal Properties of Glass, Ceramics and Glass-Ceramics.

Hagg, H. E., *The Glass Industry*, Vol. 44, No. 10, 1963, 563.

Properties discussed are thermal expansion, thermal conductivity and specific heat. Much of the data concerns materials produced by Corning Glass Works. The information of unusual properties possible in these systems will be of great usefulness in the future.

GLASS-SUPPORTING

(59) Shaping Expanded Polystyrene for Protecting Glass.

Yorke, S. G., *J. Brit. Soc. Sci. Glassblowers*, Vol. 1, No. 1, 1964, 16.

Describes a "saw" made of an electrically heated wire for the blade to cut the polystyrene.

GLASSWORKING—HISTORY

(60) Development of Scientific Glassblowing in England.

Yorke, S. G., *J. Brit. Soc. Sci. Glassblowers*, Vol. 1, No. 1, 1964, 8.

This describes and traces the history of Scientific Glassblowing in England

GLASSWORKING—MACHINES

(61) What is important in the Glassworking Lathe.

Fusion, Vol. 11, No. 2, 1964, 21-3.

Short essay on the essential features of a glass lathe.

(62) The Use of Glassworking Lathes.

Burrow, J. H., *J. Brit. Soc. Sci. Glassblowers*, Vol. 1, No. 2, 1964, 25-6

Report of a lecture, discusses features on the lathe, historical development, burner types and a few special uses.

(63) High Frequency Electrical Heating of Glass.

Yorke, S. G., *J. Brit. Soc. Sci. Glassblowers*, Vol. 1, No. 2, 1964, 24-5.

Report of a lecture, covers short account of the early work in this field, describes the generator of the H/F and method of use

(64) Cutting Machine for Refractory Tubes.

Conaboy, J., *J. Brit. Soc. Sci. Glassblowers*, Vol. 1, No. 2, 1964, 32.

This describes an attachment to a standard glassworking lathe for cutting and facing tubes using diamond impregnated wheels.

(65) **Glass Lathe Sealing—Electronically.**
Raushey, J. and Smith, M. H., *Fusion*, Vol. 11, No. 2, 1964, 19-20.

Gives a short description of the H/F heating of glass for straight seals.
See also 82.

GLASSWORKING—METHODS

(66) **New method to cut Borosilicate Ware.**

Knisely, S. E., *Fusion*, Vol. 11, No. 1, 1964, 18.
Describes the very old method of rotating glass in a lathe, scratching and heating tangentially with a small flame.

(67) **How to make Reproducible Capillaries for Etching Assemblies.**

Cassidy, *Fusion*, Vol. 11, No. 1, 1964, 19.

The method described uses gravity to produce the capillaries after heating the tube, in much the same way as silica fibres can be produced.

(68) **Ball Joint Holder.**

Taylor, R. K., *Fusion*, Vol. 11, No. 1, 1964, 22.

Describes with sketch a holder for use when working near to the joint when insert holder impracticable.

(69) **Holder for making Dewar Seals.**

Taylor, R. K., *Fusion*, Vol. 11, No. 1, 1964, 22-3.
Describes with a sketch a holder which enables the inner member to be held whilst blowing the seal.
See also 75, 76.

GLASSWORKING—TOOLS

(70) **Carbon Lathe Tools.**

Smith, D. W., *J. Brit. Soc. Sci. Glassblowers*, Vol. 1, No. 2, 1964, 32.

This note describes the construction of carbon tools such that the handle is rigidly held to the paddle.

PUMPS—CIRCULATING

(71) **Circulating Pump and Flowmeter for Kinetic Reaction Apparatus.**

Kallo, D., Preszler, I., and Payer, K., *J. Sci. Instrum.*, Vol. 41, No. 5, 1964, 338-9.

Description of the apparatus is given. The pump is double acting, the piston being of steel and the cylinder and valves of glass. The pump is operated by a square-wave generator. The flowmeter is of simple construction, the gas hitting a nickel plate which moves on agate needle bearings.

SAFETY

(72) **Misuse of Glassworking Equipment.**

Christie, H., *Fusion*, Vol. 11, No. 1, 1964, 17.

Discusses the misuse of equipment which may occur when used by others or when co-operation goes too far.

(73) **Use of Glass Annealing Oven as a "Burn-Out" Oven.**

Gray, L. E., *Fusion*, Vol. 11, No. 1, 1964, 20-1.

Describes the damage caused to oven when used to "burn-out" partially polymerized residues in glass tubes. Lists preventive measures.

SEALS—CERAMIC TO METAL

(74) **Application of Ceramic to Metal Sealing to Atomic Energy Problems.**

Gibbons, W. F., *Special Ceramics*, 1963, pp. 447-468.
The many present day and possible future uses of ceramics in the atomic energy field are reviewed with special references to ceramic-to-metal seals.

SEALS—GLASS TO CERAMIC

(75) **Mullite 671 to Glass Seals.**

Porter, E. G., *J. Brit. Soc. Sci. Glassblowers*, Vol. 1, No. 1, 1964, 16.

Describes butt seal. Gives method for preparing the end of the mullite tube. A sealing glass (e.g. C9) is sealed to Pyrex, the sealing glass is then sealed to the mullite.

(76) **Procedures and Techniques for Sealing Ceramic Mullite (body No. MV30) directly to Pyrex (7740) Brand Glass.**

Tozer, W. H., *Fusion*, Vol. 11, No. 1, 1964, 13-4.
Method given for butt seal.

SEALS—GLASS TO METAL

(77) **Notes on the manufacture of Tungsten to Silica Seals.**

Radford, R. A., *J. Brit. Soc. Sci. Glassblowers*, Vol. 1, No. 1, 1964, 15-16.

The Tungsten rod is first glassed with G.S. 10 and this is then sealed to the silica.

STEAM DISTILLATION

(78) **An Apparatus for Determining Small Amounts of Alcohol in Sour Milk and Urine.**

Andrews, R. E. S. and Cooper, P. J., *Analyst*, Vol. 89, 1964, 272-5.

Details are given for the construction of the steam-distillation apparatus, all ground-glass joints are coated with P.T.F.E.

STOPCOCKS

(79) **Improved Greaseless Valves.**

Sewell, P. R., *Chem. and Ind.*, Nov. 16th, 1963, p. 1834.

Modifications to Springham Greaseless Stopcock, can be used on high vacuum lines.

THIN FILMS. See 80.

ULTRA HIGH VACUUM

(80) **Conversion of a Standard Vacuum Evaporator to the Ultra High Vacuum Range.**

Bullis, L. H. and Taylor, K., *J. Sci. Instrum.*, Vol. 40, No. 10, 1963, 508-9.

Short note on this using an ion pumped liquid nitrogen cooled chamber addition.

ULTRA HIGH VACUUM VALVES

(81) **Ultra High Vacuum Bakeable Metal Taps.**

Engineering, Vol. 197, Jan. 3rd, 1964, 10.

Details are given of a new all metal tap constructed of stainless steel and copper, all joints are Argon-arc welded.

ULTRASONICS

(82) **Ultrasonic Drilling of Ceramics.**

Legge, P., *Industrial Diamond Review*, Vol. 24, No. 278, 1964, 20.

Describes the advantages of metal bonded diamond probes for ultrasonic drilling over the conventional, with rates of penetration, the latter often ceasing at 1/2 in. depth.

VACUUM TECHNIQUES

(83) **An Easily Exchangeable Lead in Electrode used in High Vacuum Technique.**

Franke, H. G. and Kraft, O., *J. Sci. Instrum.*, Vol. 40, No. 10, 1963, 502-3.

Method of leading in an insulated high vacuum tight wire through a metal wall.

(84) **A Self-Extracting Search Probe for the location of leaks in Vacuum Apparatus.**

Pacey, D. J., *J. Sci. Instrum.*, Vol. 41, No. 6, 1964, 398.

The probe consists of two coaxial stainless steel tubes, the search gas being carried in the inner one, the excess is removed through the outer by a gentle vacuum. This is useful when the search gas is helium as the area of the apparatus being tested for leaks is reduced to a minimum thus reducing the diffusion of gas through the glass.

WELDING

(85) **A Simple Technique for Spot Welding Molybdenum.**

Saunders, A. P., *J. Sci. Instrum.*, Vol. 41, No. 2, 1964, 112.

Describes the technique of using a solution of KOH on the surfaces to be spot welded, the weld is then made as usual but without an inert gas atmosphere.

(86) **Electric Butt-Welding of Platinum Wire.**

Weckler, Q. S., *J. Sci. Instrum.*, Vol. 40, No. 11, 1963, 543.

Details of the method given, gives greater control over temperature than with a flame.

FREE-PISTON PIPETTES & BURETTES — RECENT DEVELOPMENTS

Talk given by Mr. I. C. P. Smith of E.R.D.E. Waltham Abbey, Essex to the Southern Section, B.S.S.G., on 23rd October, 1963

THE design of the free-piston pipette was first published by the writer in "Chemical Age" in October, 1946, and was the subject of a U.K. patent. It was before its time but was made spasmodically in this country; it is now being produced by Jencons and Flaigs. In the meantime, in 1956, it has been separately invented in Sweden and is the subject of a Swedish patent.

To obtain the best results with the pipette the piston must be a very good fit in the barrel, clearance of the order of 2 to 3 μ , such that the leakage rate past the piston should be less than one drop in 10 minutes. Hydraulic shock error may be minimised by controlling the inflow rate. By attending to all details, and making all the necessary corrections, a free-piston pipette has been giving 10.0000 ml. \pm 0.0002 ml.

The pipette is being used successfully for pointing in graduating.

An Accurate Liquid Metering Device

The free-piston pipette has been modified for mechanical drive, as shown in Fig. 1, using a special form of flat-face control valve, with bores and annular channels so designed that when it is rotated at a uniform slow rate, e.g., 6 r.p.m., it allows sufficient time of opening in each phase, before stopping and changing to the alternate phase, to give each discharge, thus giving four dischargers per revolution of the valve. Constructed with an 11 mm. bore barrel and an adjustable stop, this gave up to 5 ml. per shot, and formed a very accurate shotwise liquid feeder giving better than 0.05 per cent constancy. It is independent of the viscosity of the liquid, and practically independent of temperature.

Gas-Metering Device

The mechanised, free-piston pipette has been constructed in a modified form to handle a very slow gas flow, as shown in Fig. 2. A gas would not operate the piston properly in dry conditions and in this form the cylinder is filled and the two side barrels partly filled with a suitable inert liquid, this liquid rising and falling in either side in turn with each discharge. The gas volume passed is still a function of the travel of the piston in the barrel, but the pressure in the gas on the upstream and particularly on the downstream sides of the pipette must be controlled and observed and suitable corrections made.

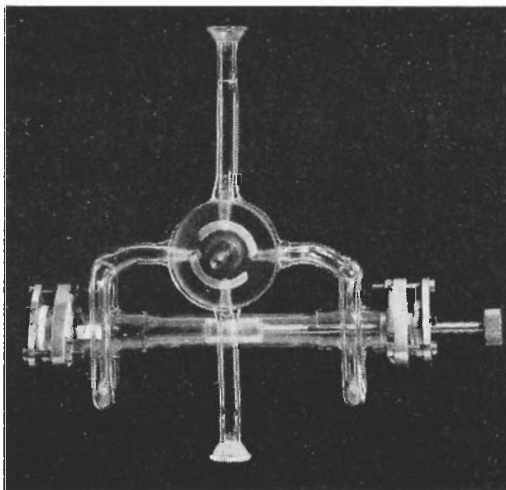

FIG. 1

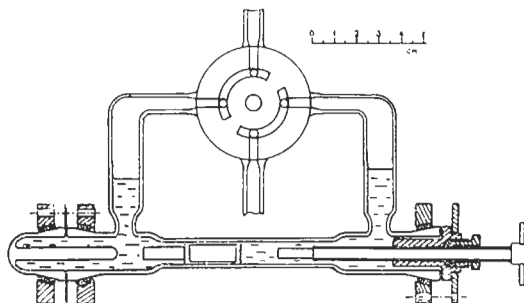

FIG. 2

Free-Piston Burettes

The free-piston burette was first described in 1956 (U.K. Patent No. 860,670) when it took the familiar upright 50 ml. form. Difficulties had been experienced in obtaining precision-bore tubing of suitable accuracy of bore, and special air-gauges had been constructed to check for "lobing," as well as sufficient constancy and perfection of the bore over the length. Those at present constructed by Jencons are of a very high order, and include, in the upright series, 50 ml. and 100 ml. burettes and 5 ml. and 10 ml. micro-burettes. Important additions are the horizontal burettes, 5 ml. in 0.02 ml., reading by vernier to 0.002 ml. for micro-chemical use, and 25 ml. and 40 ml. in 0.1 ml., reading by vernier to 0.01 ml. Micro-chemists find the small size a considerable improvement in accuracy over ordinary burettes, as in the latter any small irregularity in the liquid film left on the wall represents a large error. The convenience and comfort of using horizontally operating burettes have to be experienced to be fully appreciated.

An unusual modification is the inverted free-piston burette (Fig. 3). It has two advantages, the one compactness, in that its overall height from the bench is little more than the graduated length, and the other that it may be simply immersed in a tube for temperature control.

Certification of Graduated Ware

Free-piston burettes have been operated with such accuracy that they may be used for certification, particularly for works purposes, of such articles as volumetric flasks. For this purpose, it would be convenient to set up in a constant temperature room a 100 ml. (or 101 ml.) free-piston burette reading to .02 ml., by vernier, constructed for horizontal operation and carefully standardised beforehand; this could then be used for standardising a number of sizes of volumetric flasks or other similar articles.

Glassblowing Notes

In the liquid feeder, the barrel was made of high-grade, precision-bore tubing, checked for lobing and, after joining the $\frac{3}{8}$ in. pipe-ends and annealing, the barrel was lapped out, with a tool cast in type metal in a piece of the same P.B.T., with the finest alundum powder (No. 125). The two discs from which the valve was constructed were trepanned out of pressed Pyrex plate ($\frac{1}{8}$ in.), using a steel tube and 220-mesh Carborundum. The static part was faced and carefully marked out, and drilled from the face and from the edge. It was heated to 600°C in a furnace before

joining on the side tubes. For forming the annular grooves in the rotor, this was held in the chuck of a lathe and ground out with a small diamond wheel run from a flexible drive, held in the tool post. The piston was made oversize, annealed, and ground all over in a Myford cylinder grinder.

Crown copyright is reserved for the liquid and gas-metering devices: these were made by Mr. R. Watkins of E.R.D.E.

I. C. P. SMITH

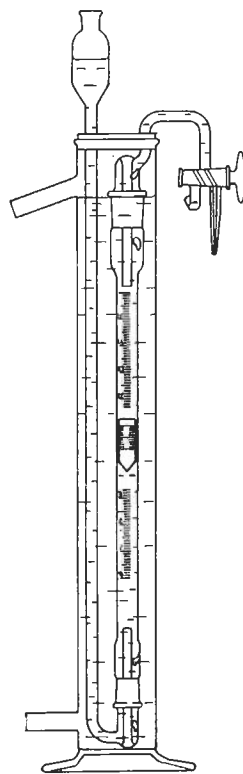

FIG. 3

GRADUATION LINES ON BOROSILICATE GLASS

Talk given by Mr. I. C. P. Smith of E.R.D.E. Waltham Abbey, Essex, to the Southern Section, B.S.S.G., on 23rd October, 1963

On graduated ware made from soda-lime glass, a line thickness of 0.1 to 0.15 mm. has been habitual, and is readily obtained employing HF between 40 per cent and 70 per cent strength, and the usual beeswax resist. With borosilicate glass the same combination frequently results in an etched line of bad form, and a line thickness of anything up to 0.3 mm. Such a line detracts from the appearance of the article, and may lead to errors in reading. The addition of concentrated sulphuric acid to the HF improves the form of the line, and Fig. 1 shows in section such lines produced on Pyrex glass, using equal volumes of HF and concentrated sulphuric acid, and Poth-Hille resist No. 6,544. The lines are 1 mm. apart, indicating that they are approximately 0.15 mm. wide; however the corners are rounded, and there is a bevel running away from the groove for more than 0.1 mm. on either side. where the acid had penetrated

under the resist. Fig. 2 shows in section etched lines made on Pyrex glass, using a mixture of 100 ml. of 40 per cent HF and 30 gm. of ammonium bifluoride. In this case the grooves finish with nearly sharp corners, and they have no additional bevel. These grooves feel quite sharp to the finger-nail, compared to grooves made with any other acid mixture; they also fill cleanly with pigment. Those shown in the figure were made using the same Poth-Hille resist, but better results with narrower lines were obtained using beeswax with 7 per cent by weight of optical pitch (*E. Hardman's Ref. SR3/0/135*). The HF-bifluoride is much less objectionable both to make up and to use than the HF-sulphuric mixture, being very much less subject to fuming, although the etching times required may be a little greater. Means may, however, be employed of not losing production accordingly.



FIG. 1



FIG. 2

I. C. P. SMITH

THE DEVELOPMENT OF A NEW FORM OF HEMPEL PIPETTE

We have been using Hempel Pipettes for some years on our gas analysis equipment and have found the conventional design to be difficult to clamp, fragile and bulky.

These faults became very acute when we started to develop a portable form of the equipment and, in an attempt to improve the situation, the design shown in the figure at B was born. This design saved a great deal of space and was strong but in use was found to be difficult to clamp and was also liable to cause vortex formation. On some occasions the vortex formed was marked enough to break down the

seal between the compartments. Vortex troubles were overcome by pushing in fingers of glass round the diameters of the cylinders in a similar fashion to that employed when making a Vigreux fractionating column (*see B1 in figure*).

The design shown at C was a logical development from B. It is strong, easy to clamp, compact, and the tubes running through the cylinders prevent vortex formation.

B. LAYZELL
The Metal Box Co. Ltd.
Research Department
Acton, London, W.3

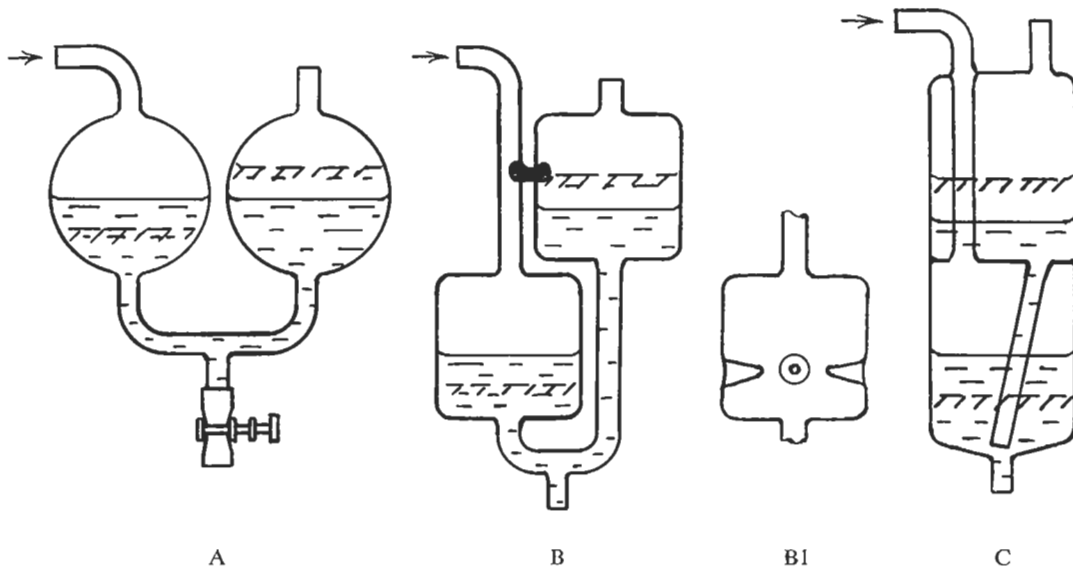

QUESTIONS AND ANSWERS

Q. How can you avoid bloom when sealing Spectrosil windows.—R. J. W. Harvey.

A. There have been various suggestions, including sealing with the window hot in the shortest possible time; drop sealing so that

flames do not play directly on window and alternative jiggling methods. In view of the impending symposium on fused silica, we think it advisable to defer a final answer as this may be one of the topics discussed.

ADDITIONS TO LIST OF MEMBERS

Full Members

Brereton, W.	Chemistry Department, University College, London, W.C.1	
Darvall, J.	U.K.A.E.A., Aldermaston, Berks ...	"Berkeley," Rosewood Hall, Pangbourne, Berks
Eyre, E. T.	Standard Telephone Laboratories, Harlow, Essex	24 Woodlands Road, Hertford, Herts
Fettis, W. H.	Science Laboratories, University of Durham	8 Springwell Avenue, North End, Durham
Finnie, G. A. S.	Chemistry Department, University of Aberdeen	50 Leggart Terrace, Aberdeen
Fowler, M. J.	Medical School, Bristol University ...	1 Plum Tree Close, Winscombe, Somerset
Francis, C. A.	Anchor Glass Co. Ltd., North Circular Road, N.W.2	12 Woodside Grove, London, N.12
Griffith, T. I.	Chemistry Department, University College of Wales, Aberystwyth	Aroha, Llandre, Bow Street, Cards
Hawkins, M. D.	College of Technology, Corby, Northants	33 Naseby Street, Northampton
Henry, W. T.	Howards of Ilford, Ilford, Essex ...	73 Flamstead Road, Dagenham, Essex
Hodder, S. G.	Fison's Scientific Apparatus Ltd., Loughborough, Leics	1 Colgrove Road, Loughborough, Leics
Jennings, R. W.	12-14 Stoney Street, Nottingham ...	
Jones, D.	H. J. Elliott Ltd., Pontypridd, Glamorgan	43 Bryn-y-Fran, Trethomas, Newport, Glamorgan
Kapur, D. K.	B.I.P. Chemicals Ltd., Oldbury, Wores	2 Sycamore Paddock, Oakfield Road, Stourbridge, Wores
Keating, H.	Biochemistry Department, University College, Cork	
Kember, J. H.	U.K.A.E.A. Warrington, Lancs ...	9 Beechmill Drive, Culcheth, Warrington, Lancs
McRobbie, J.	R.O.F. Bishopton, Ayrshire	88 Manchester Drive, Glasgow, W.2
Maple, T. J.	Queen Mary College, London, E.1 ...	1 Sandhurst Road, London, N.W.9
Masson, C.	I.C.I. Ltd. (Nobel Division), Stevenston, Ayrshire	1 Milngarholm Avenue, Irvine, Ayrshire
Nelles, R. W.	W.R.E. Salisbury, South Australia ...	21 Elmgrove Road, North Salisbury, South Australia
Palin, A.	I.C.I. Mond Div., Winnington, Northwich, Cheshire	"Hilbre," Kelsall, nr. Chester
Reader, R. C.	Anchor Glass Co. Ltd., North Circular Road, N.W.2	76 Kenwyn Drive, Neasden, N.W.2
Roebuck, J. R.	Ralph Cuthbert Ltd., Huddersfield, Yorks	24 Grasscroft Avenue, Honley, Huddersfield
Spear, E. W.	College of Science and Technology, Bristol 7	
Stuart, H.	Scientific Glassblowing Co. Ltd., 32 Milton Street, Manchester 13	
Taylor, W.	I.C.I. Ltd., Alderley, Cheshire ...	Thornfield Cottage, Twemlow Green, Goostrey, Cheshire

Associate Members

Barrett, G. E.	Thermal Syndicate Ltd., 9 Berkeley Street, W.1	11 Lansdowne Road, Staines, Middx
Bishop, P.	Davey & Moore Ltd., Enfield, Middx	2 Speldhurst Close, Haylesford Park, Bromley, Kent
Noirot, M.	Sovirel, Bagncaux-sur-Loing, Seine et Marne, France	
Davis, G.	Thermal Syndicate Ltd., Wallsend-on-Tyne	106 West Percy Street, North Shields, Northumberland
Dowden, W. F.	Aimer Products Ltd., Rochester Place, London, N.W.1	
Eaton, J. D.	Fisons Scientific Apparatus Ltd., Loughborough, Leics	2 The Close, Towton, Tadcaster, Yorks
Gallagher, J. P.	Fisons Scientific Apparatus Ltd., Loughborough, Leics	Whitehorse Cottage, Wareside, Ware, Herts
Gallivan, J.	Houldsworth School, University of Leeds	506 York Road, Leeds, 9
Gordon, J.	Laporte Acids Ltd., Castleford, Yorks	162 Ring Road, Middleton, Leeds, 10
Lee, N.	Cheadle Hulme School, Claremont Road, Cheadle Hulme, Cheshire	
O'Neill, H. D. D.	Pharmacology Department, Leeds Medical School	30 Primley Park View, Leeds, 17
Poulten, J. H.	John Poulten Ltd., Tanner Street, Barking, Essex	
Wheatley, W.	Department of Electrical Engineering, University of Leeds	12 Hollin Mount, Headingley, Leeds, 16

Student Members

Murray, J. W.	Fisons Scientific Apparatus Ltd., Loughborough, Leics	30 Lucknow Avenue, Mapperley Park, Nottingham
Phillips, G.	Chemistry Department University College of Wales, Aberystwyth	Elgar, Llandre, Bow Street, Cards

CORRECTION—FULL MEMBER

Shepherd, I.	A.E.I. Ltd., Rugby	75 Charlesfield Road, Rugby, Warwicks
---------------------	---------------------------	---------------------------------------

LATEST NEWS

A Seminar is held annually at The College of Ceramics, Alfred University, New York, on subjects required by scientific glassblowers. This Seminar is run in conjunction with the American Society of Scientific Glassblowers.

This year at the close of the lecture session, a simple practical test was instituted, and it is hoped that this will lead to more advanced examinations and the eventual granting of diplomas up to Master craftsman standards.