

JOURNAL

OF THE

BRITISH SOCIETY OF SCIENTIFIC GLASSBLOWERS

Vol. 3

DECEMBER 1966

No. 4

JENCONS TYSLIDE

A versatile saw and grinding bench for the glass and ceramic worker. Supplied complete with cross fence, fitted adjustable stop, wheel guard and plastic coolant container. Heavy duty $\frac{1}{2}$ h.p. motor, 220/240 volts A.C.

The moving table enables materials $6\frac{1}{2}$ in. in size to be cut simply, by sliding the table forward.

Grooving and slitting to great accuracy.

Cup and peripheral wheels are interchangeable with the diamond wheel.

Angle cuts · Slide preparation
Grinding · Slitting · Grooving

Bench model also available. Further details of Jencons cutting equipment on request

HAVE YOU RECEIVED YOUR CATALOGUE!

A dictionary of glassworking equipment now available

Sole Agents—

Jencons of hemel hempstead

JENCONS (Scientific) LTD., Mark Road, Hemel Hempstead

Telephone: Hemel Hempstead 4641



CONTENTS

	Page
Editorial	49
Applications of Carbon and Graphite in the Glass Industry	50
Abstracts	21A, 22A
Leeds Colloquium	61
Section Activities	63
Letters	65
American Symposium Papers	66
Library	xv

Editor

J. H. BURROW

H. H. Wills Physics
Laboratory

Royal Fort Clifton, Bristol

Advertising & Business
Manager

J. A. FROST

Chemistry Department
University of Reading

Distribution, Finance and
Society Registrar

D. A. HENSON

3 Oliver Drive
Calcot, Reading

Abstracts

S. D. FUSSEY

A.W.R.E., U.K.A.E.A.

Aldermaston, Berks

Why wait . . . ?

QUICKFIT AND QUARTZ
EDWARDS HIGH VACUUM
HIGH VACUUM STOPCOCKS
ELECTROTHERMAL AND
GENERAL APPARATUS

IMMEDIATE EX-STOCK DELIVERIES

We sell service

A. D. WOOD (LONDON) LTD

SERVICE HOUSE
1 LANSDOWNE ROAD
TOTTENHAM, LONDON, N.17

Telephone : TOTtenham 0736-7-8-9

WE
STAMP
OUR
SYMBOL
ON
EVERYTHING
OF
QUALITY...

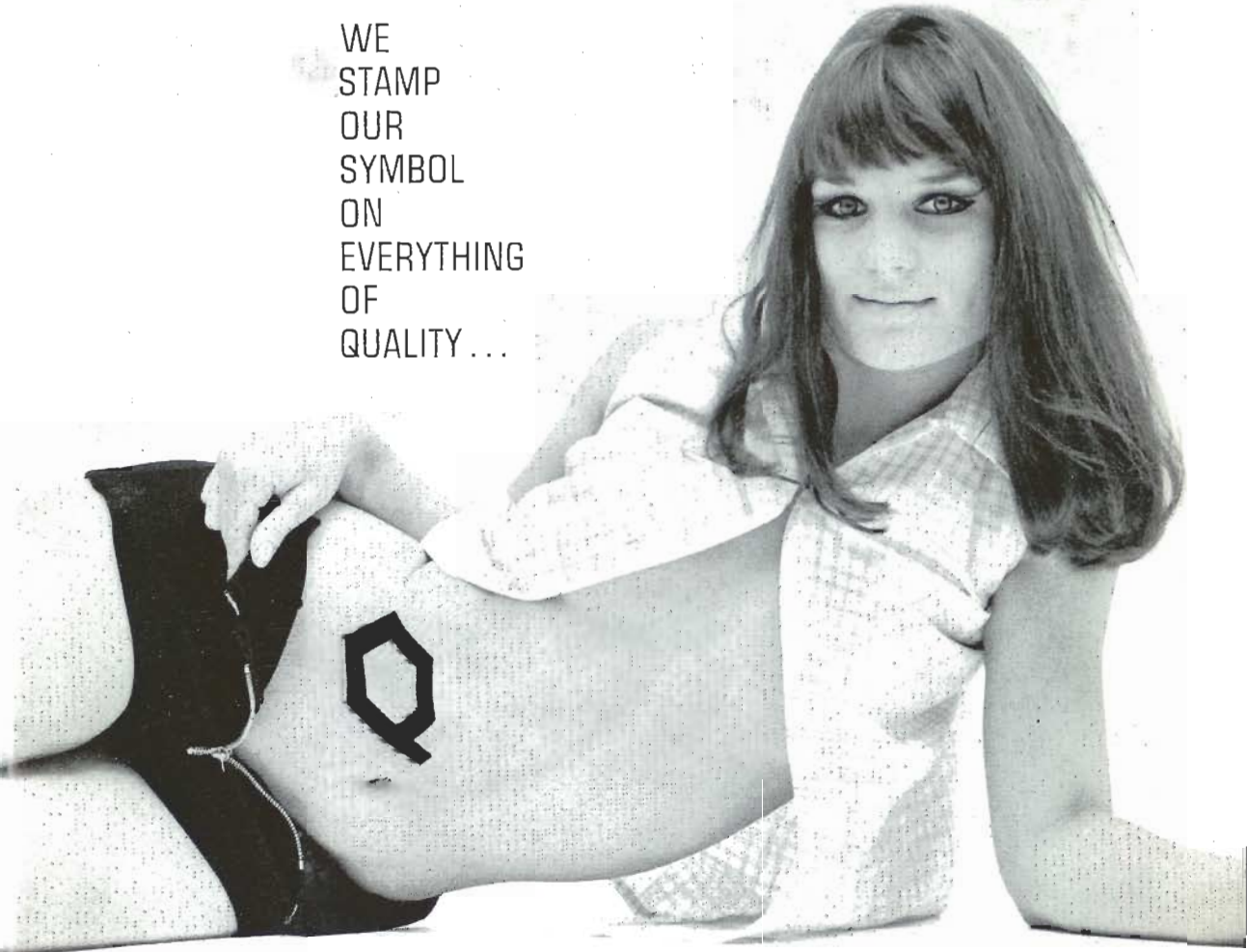

INCLUDING
QUARTZ



QUARTZ FUSED PRODUCTS LIMITED

RONEC WORKS · GOVETT AVENUE · SHEPPERTON · MIDDLESEX · WALTON-ON-THAMES 23870

HIGH SPEED SAW

AUTOFLOW

- ★ ROBUST CONSTRUCTION
TO PRECISE LIMITS
- ★ USES "DIAGRIT"
DIAMOND IMPREGNATED
DISCS

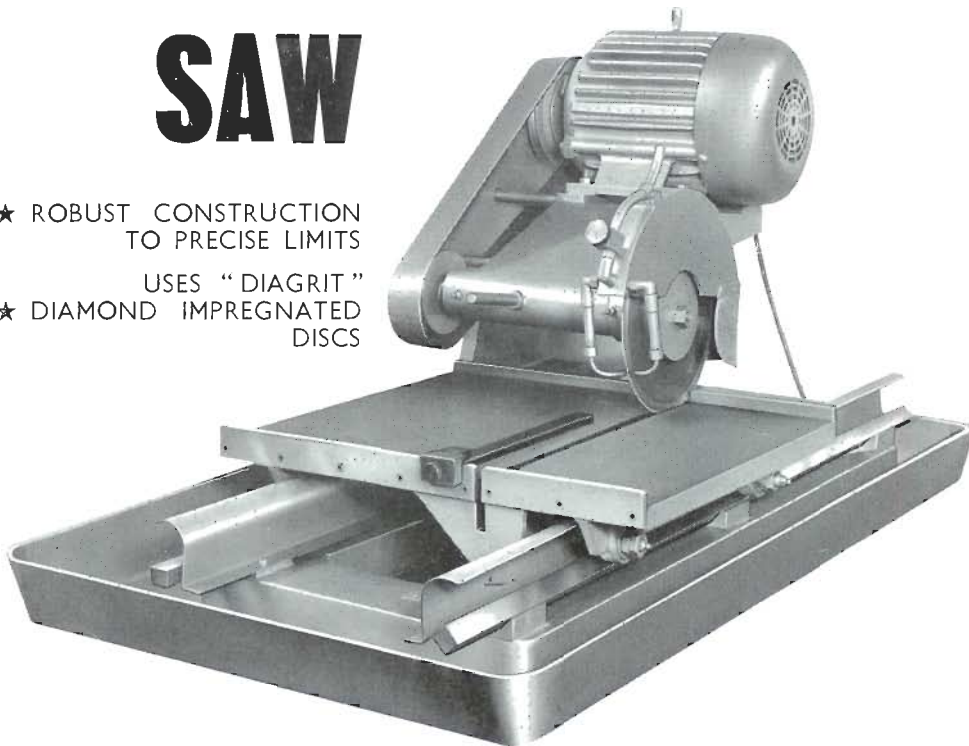

For cutting

FIREBRICKS, REFRACTORIES
CERAMIC AND GLASS

For full details write to

AUTOFLOW ENGINEERING LTD

LAWFORD ROAD, RUGBY Tel.: RUGBY 6341

Sole distributors for "Diagrit" Diamond Impregnated Tools



Registered Trade Marks



The craftsmen of Quickfit

In the purpose-built factory at Stone, Staffordshire, the men of Quickfit apply their skills to produce the best range and quality of laboratory glassware in Europe.

QUICKFIT & QUARTZ LTD., STONE, STAFFS. Tel: STONE 2121. Telex: 36226

EXE GLASS LATHES

are not only precision built but have proved they maintain their accuracy after many years of constant use. They have many special features including an unusually wide speed range which covers tube coiling to centrifugal action

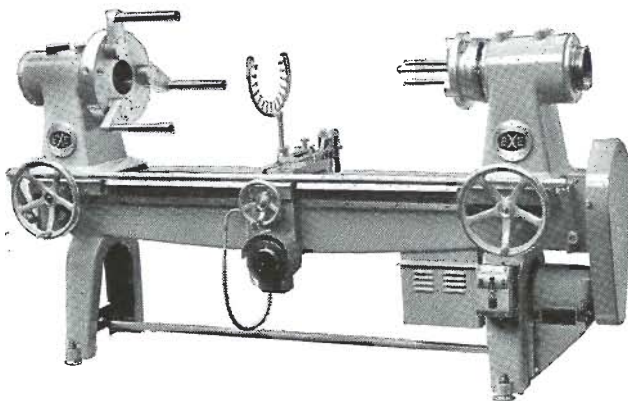

Many years' experience of development and production of Glassworking Lathes enable us to offer a wide range of LARGE, MEDIUM and SMALL LATHES suitable for research and production purposes

When enquiring please state your requirements, including distance between spindles, swing and spindle bore also the general purpose

THE EXE ENGINEERING CO. LTD
EXETER ENGLAND
Telephone Exeter 75186-7

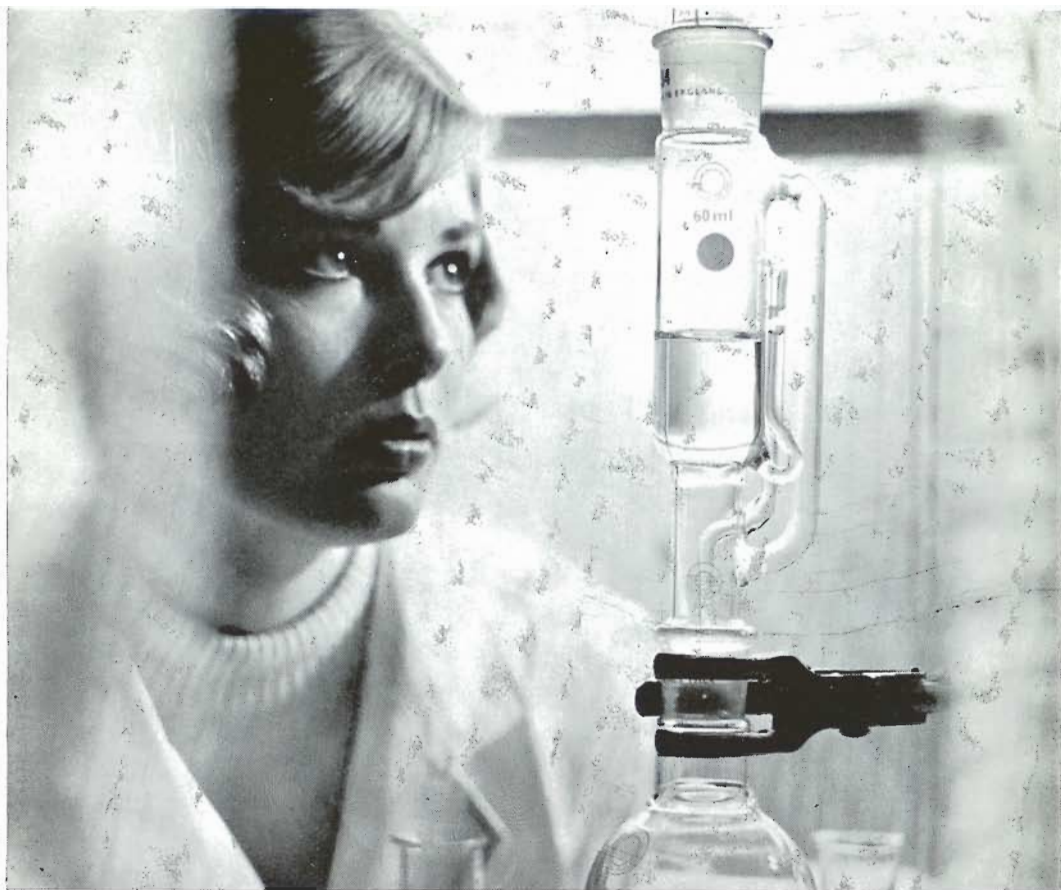

To be precise—PYREX® laboratory ware by Jobling

PYREX® laboratory glassware offers the highest standards of precision. Consistent quality and durability. And competitive cost. It is produced in a range to meet every known need. (Should new problems arise, expert design and research teams are ready to supply the best possible answers). If you ever encounter difficulty in obtaining PYREX® immediately, contact Jobling, the manufacturers. Always be precise—ask for PYREX® by name.

1:5 P.T.F.E.

PLUG STOPCOCK

Leak free. Never freezes, or seizes (even with alkali). 1:5 taper means ease of turning with precision - no lubrication needed.

SINTERS

PYREX® sintered ware offers fast, efficient filtering. Unaffected by nearly all

common reagents - either acid or alkali. The range covers all requirements.

INTERCHANGEABLE JOINTS

Compact, easily replaceable components for routine work (number of joint sizes strictly controlled). Highest quality joints conforming to International and British Standards.

DISCOVERIES ARE MADE IN **PYREX®** (JOBLINGGLASS)

® Registered Trade Mark

JAMES A. JOBLING & CO. LTD. WEAR GLASS WORKS, SUNDERLAND, ENGLAND. Telephone : 57251. Telex : 53146



SENSITIVE NEEDLE VALVES

For Gas, Air, Oxygen and Steam, etc

GAS, AIR & OXYGEN BURNERS

For Radio Valve and Electric Lamp Manufacture
Scientific Glassblowing, etc

HIGH PRESSURE BURNERS, INJECTORS, ETC

For Mechanised Brazing, Silver Soldering and
other Heating Operations

W. S. A. ENGINEERING CO. LTD

5-9 HATTON WALL, LONDON, E.C.1

Telephone : HOLborn 6175-6

Telegrams : Wilbranda. Smith. London

British Society of Scientific Glassblowers

Founded 1960

Chairman

E. G. EVANS
65 Frambury Lane
Newport, Essex

Secretary

D. W. SMITH
"Greenridge", Frome View
Frampton Cotterell, Glos.

Treasurer

F. A. BRANFIELD
15 Grosvenor Road
London, E.7

EDITORIAL

THE letters which appear in this issue are some evidence that the September editorial has, as was intended, stimulated thought and discussion on Society activities and the one by J. Price expresses in a masterly way the outlook of many members. Some of us are convinced of the desirability of a system of certification in the belief that the status of the Society will be raised, the difficulty being how to present the scheme in a form that will be acceptable to both present and future members.

No doubt this will in the fullness of time be resolved, the lesson being that we must give adequate time to assess the consequences before making changes in our rules, as it is difficult with our present form of representation to obtain the views of the large number of passive members.

It is possible that as the Society grows a more direct approach to members will be necessary when a vital change is under consideration.

The précis of the letter by J. Kay also deserves careful consideration as it reveals a certain disparity among our members, some fully supported by their employers, are free to travel in order to gain experience of other glass workshops and manufacturing processes; in working time and with expenses paid. In these cases requests for new equipment are often granted, the employers in turn gaining a more productive glass workshop which they are glad to show to visitors. In contrast, we also have members whose development is retarded by having none of these advantages and who are working with the minimum of equipment. True they could try to change employment but the fact that their

experience was not gained in a progressive glass shop is no help in an application, and of course there may be personal reasons for not wishing to change.

As Mr. Kay suggests we should do everything possible to help these cases when they are brought to our notice. Certainly when large scale meetings such as Society Colloquia are being arranged we should bear in mind young members and others who cannot afford to attend and for them a scheme of limited subsidy might be considered.

In this way we would secure a better representation of membership and promote goodwill among a group of Society members whose loyalty will be of increasing importance in future years.

J. H. BURROW
5th December 1966

OBITUARY

We regret to report the loss at the early age of 32 of Jim Cook, a member of the Southern Section who had endured ill health for some considerable time.

At the age of 26 he had established himself as a first-class craftsman and in 1960 was appointed to the senior position at the British Coal Utilisation Research Association.

He was a keen member of the Sports and Social Club at his place of employment, golf and tennis being his main interest, though in earlier years he was a successful racing cyclist. He will be sadly missed by past and present colleagues and all who knew him. Our sympathy is extended to his wife and son.

F.J.L., 6th October, 1966

Contributions for the March issue should be sent in by January 31st, 1967

Subscriptions for 1967 are now due and the Treasurer will appreciate early payment

The Journal is published quarterly by the B.S.S.G. and is available free to members and at 10s. 0d. per copy (or 35s. 0d. per annum) to non-members. A limited number of back copies are available. Editorial communications should be addressed to the Editor, c/o H. H. Wills Physics Laboratory, Royal Fort, Clifton, Bristol 8, and enquiries for advertising space to J. A. Frost, Chemistry Dept., University of Reading. Printed in Gt. Britain by E. G. Ellis & Sons, Willow Street, London, E.4. © B.S.S.G. and Contributors, 1966.

THE APPLICATION OF CARBON AND GRAPHITE IN THE GLASS INDUSTRY*

by J. C. CAMPBELL (Senior Development Engineer)

Morganite Carbon, Battersea Church Road, London, S.W.11

1. Historical

THE first known uses of glass were for purely ornamental purposes, and date back to the Third Millennium B.C. Glass vessels did not appear until the middle of the second millennium, when liquid or softened glass was poured over a clay core to produce the form. Alexandrian workers knew the art of blowing in moulds, which is illustrated by paintings in the tombs of Beni Hassan near Thebes (*circa* 2000 B.C.). Much Roman blown glass was of good form and proportion, the use of a blowing iron appearing

glass appears in "De Re Metallica" about 1550. The first manufactured English glass appeared during the 15th century. From the 11th to the 19th century the art of glass forming and shaping progressed slowly, and was based on highly skilled crafts using the most primitive form of tools. Figure 1 illustrates a typical workbench and some forming tools of this period.

During the latter half of the 19th century, mechanisation of the industry was introduced, and progressed to a very high degree during the

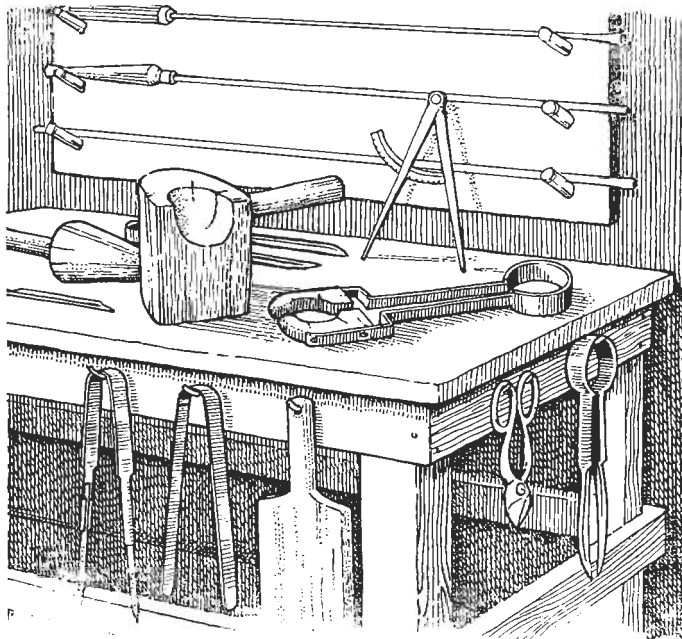

Early tools and formers were often made from, or faced with wood. Carbon, with its high chemical inertness non-wetting properties, thermal conductivity, resistance to thermal shock and excellent machinability, is widely used today, not only as a replacement for wood in conventional tools, but as an ideal medium for the complex jigs, formers and templates used in such advanced techniques as glass sintering and centrifugal forming.

FIGURE 1

about 50 B.C. The tradition, however, deteriorated in the Dark Ages and Mediaeval bottles were simply a bulb with a long neck. A record compiled about A.D. 1000, describes the making of sheet or "broad" glass, by blowing a cylinder, removing the ends, splitting lengthwise, and then flattening. The influence of Venice became pronounced from 1250 onwards, upwards of 8,000 men being employed. A dissertation on

next fifty years. Latterly and up to the present time progress has been mainly concerned with the sophistication of these earlier methods of mechanisation. It is, however, quite extraordinary that although the production of industrial glass has become highly mechanised, the more elegant forms and accurate requirements of glass ware continue to be hand crafted by traditional methods.

* Talk given to the Southern Section of the British Society of Glassblowers, 11th May, 1966.

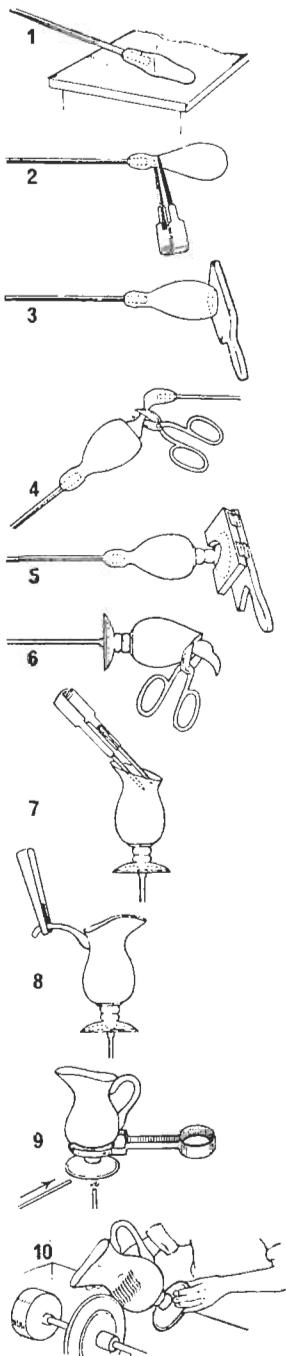

Typical stages in hand manipulation of glass :

1. The "gather" on the end of the blowing iron is roughly shaped by rolling on a table or "marver" faced with carbon.

2. The glass is blown and tooled to shape the neck. The tongs have carbon inserts.

3. The end is flattened on a bat-shaped former called a "battledore", once made of wood, but now carbon faced.

4. The solid stem is shaped separately on a "punty iron", attached to the flattened end of the jug and cut off with shears.

5. The foot is shaped between the carbon "leaves" of a "clapper".

6. The foot is supported on a punty while the unwanted glass attached to the blowing iron is sheared off at an angle to form the rim.

7. The rim is opened out to form a circular cone and the lip angles shaped.

8. The handle, previously formed on a punty, is attached.

9. The finished jug is held in the carbon faced tongs while the punty is snapped off.

10. Decoration by deep cutting is carried out on a diamond wheel.

FIGURE 2

2. The Characteristics of Glass/Former Contact

From this brief historical note emerges the basic factor controlling glass forming, the shape defines both forming method and the type of former required. It must therefore be appreciated that the conditions at the interface between the glass and the former are critical and have a decided influence on the form and finish of the product.

2.1 Early in glass forming practice, clay cores and moulds introduced the steam cushion effect between the hot plastic glass and the former.

2.2. The use of wood for moulds, formers and facings and for manipulating tools, showed the importance of carbon at the glass/former interface. The carbon resulting from charring of the wood in contact with the hot glass.

This paper will endeavour to trace the stages of development from these primitive moulding and forming materials to modern carbon and graphite technology.

3. Development of Mould and Former Systems

3.1 The Steam Cushion Effect

The transition from a clay former to a clay mould enabled an ill-formed shape of variable wall thickness to become one of appreciable proportion and symmetry. However, formers in this type of material were short-lived and of doubtful reproducibility. Use of wooden tools accompanied by the charring at the interface gave a longer life and better reproducibility. The practice of dipping wooden moulds into water, inhibited charring and reintroduced the steam cushion found with clay formers, further increasing life and improving reproducibility. The increased demand for identical glass shapes initiated the development of the cast iron mould faced with a mixture of cork dust and fine sawdust, capable of retaining sufficient water after dipping to create the necessary steam cushion. One of the production problems is the frequency with which this facing has to be replaced, has led to commercial carbons and graphites; inherently porous materials being suitable for blowing moulds giving a reliable steam cushion effect.

3.2 Glass Forming Tools

Referring to Fig. 1 it can be seen that the bench top or marver, the half blow mould, the cone and the battledore are

entirely made from wood, the metal tongs having wooden facings, and the squeezers wooden inserts.

After a comparatively short period, the wood surfaces in contact with hot glass become charred, but wood char does not have particularly good resistance to oxidation or wear erosion. Wood consists essentially of a duplex having a hard and soft constituent, this structure persisting after thermal transformation, the hard fibres as a hard carbon in a soft powdery matrix. It is desirable for durable service that the bulk should consist of a hard carbon with little or no soft constituent, and to meet this condition a number of artificial carbons have been devised. Fig. 2 shows how artificial carbon facings can replace the natural chars in wooden forming tools.

4. Glass Forming Tool Requirements

Development over a lengthy period has shown that carbon is the most suitable material for glass forming processes. To examine the underlying reasons for adopting manufactured carbon, the conditions at the interface of plastic glass and the former are those of a two component system, the glass as the final product being the most important.

Glass is defined as an inorganic fusion product which has cooled without crystallisation to a rigid condition. It may consist in general of a mixture of a number of metal oxides in combinations which produce an almost infinite variation of properties. It is a class of material characterised by a long viscous phase over a wide temperature range, that is to say having a gradual transition from liquid to solid.

As the final product must maintain transparent surface finish, geometric form and constitution appropriate to its particular use, in order to work, form or shape viscous glass, the tools should be made from a material having the following characteristics.

4.1 Non-contaminating

The tool material must be stable, to avoid the formation of oxides soluble in glass which would smear or discolour the product. As the oxides of most commonly used metals inconveniently behave in this fashion to inhibit contamination it becomes necessary to maintain a coating of beeswax or similar lubricant, to create a vapour film at the interface.

4.2 Non-reactive

The characteristics of glass such as refractive index, tint, etc., are dependent on constitution, therefore the oxide content must quantitatively remain unchanged.

4.3 Non-wetting

To maintain a smooth polished finish of the product, it must not stick to the forming surface. Wetting and spreading of solid/liquid/vapour systems are related to chemical reactivity of the components at the interface and to the angle of contact between them. When this angle is greater than 90 degrees wetting does not occur; when less than 90 degrees the liquid wets, and at zero degrees it spreads.

4.4 Non-chilling

Glass has a comparatively low thermal conductivity and high coefficient of expansion. Too rapid a rate of heat transfer will cause crazing and cracking. The tool material must therefore have a low thermal conductivity to avoid rapid chilling and low thermal expansion to permit accurate forming.

4.5 Low cost

For glass formers, material must be available at low cost and capable of being easily and inexpensively shaped into complex forms.

The unique properties of plain carbons and electro-graphites fulfil these essential requirements for glass forming materials. A number of refinements may be applied to these basic materials, which can make them more suitable to the wide variety of specialised operating conditions to be found in the glass industry.

As there are some fifty types of glass constitutions, the selection of a suitable grade of carbon should receive careful consideration. Selection mainly depends on working temperature, shape required and production rate. These factors all varying according to the type of glass. Up to 1000°C, carbon (CY grade) has proved suitable on account of good hardness and abrasion resistance. In excess of this temperature as oxidation erosion rates increase, electro-graphite (EY grade) should be considered, although less hard, has a lower oxidation rate, and is more inert.

In order to assist in selection of a grade most compatible with the type of glass and the working conditions, it is desirable to briefly describe the manufacturing processes of carbon and graphic and their effects on characteristics.

5. Characteristics of Carbon

Under non-oxidising conditions, graphite (crystalline carbon) is the highest temperature/stable elemental solid known. It has no liquid phase below a 100 atmospheres pressure, and even at 3,000°C its vapour pressure is only approximately 1 mm. of mercury.

5.1 Influence on method of making

From this it may be seen that the more usual methods of forming many materials, such as by melting and casting or pressing and sintering, cannot be applied to carbon and graphite. The method used therefore is to form compacts, of selected carbon powders bonded together with a carbonaceous binder, usually coal tar or pitch by moulding or extrusion. The binder is subsequently pyrolysed by heat treatment (at approximately 1,200°C), in a non-oxidising atmosphere, leaving a carbon residue, which forms high strength bonds between the particles. This results in the production of a coherent though porous material having predominantly the characteristics of carbon. The transformation into the electro-graphite form requires further heat treatment to temperatures in excess of 2,400°C.

5.2 Influence of raw material

The sources of carbon and graphite powders range from naturally occurring graphite, through coke from petroleum residues to carbon blacks derived from oils. By raw materials selection the carbon industry varies and controls mechanical, physical, chemical and thermal properties of the carbon and graphite artifacts. Fig. 3 shows some common sources and processed forms of carbon, from which it can be seen that rather like the glass industry the permutations of the basic raw materials can produce a wide variety of families of products.

5.3 Influence of heat treatment

For commercial purposes the thermal history of the material determines the name by which the types are differentiated. In general terms carbon refers to kilned materials heat treated to a temperature of about 1,250°C, and graphite to carbons subsequently heat treated to a temperature in excess of 2,400°C.

It is important to differentiate between these two categories, as their properties

are dissimilar, and the variations in behaviour play a great part in appropriate grade selection.

Commercial carbons (the CY range) compared with graphites are characterised by high hardness and good strength properties, high electrical resistance and low thermal conductivities, with higher rates of oxidation, and dimensional stabilities limited by thermal history.

Graphites (the EY range) on the other hand have lower hardness and strength, low electrical resistance and good thermal conductivity, lower rates of oxidation and are dimensionally stable in the range below the graphitising temperature.

conductivity, and oxidation rates, with similar dimensional stabilities to the more highly graphitic grades.

The physical and mechanical properties are affected by structural variations, and their magnitude determines density, porosity and texture. For example, a high density, low porosity, fine grained, close textured material, has a greater strength, than a low density, open pored, coarse grained grade. As already mentioned carbons and graphites are produced by two different methods, moulding and extrusion. The method of making introduces directional variations in characteristics related to the orientation of the lattice

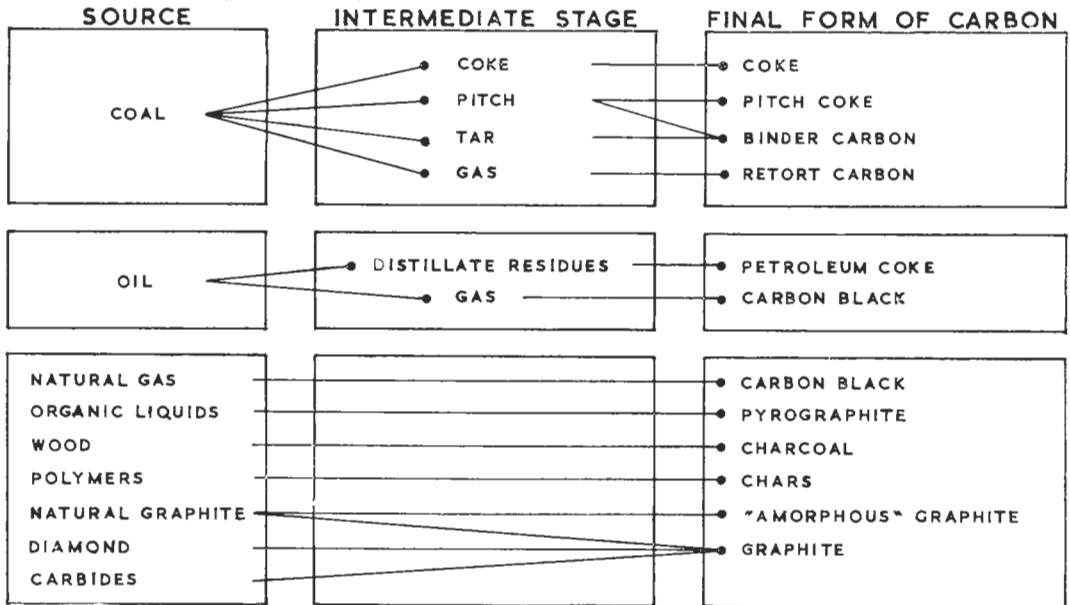

FIGURE 3

Common Sources and Final Forms of Carbon

As the property differences between predominantly carbon and predominantly graphite grades can be widely diverse, an intermediate range of materials, generally known as graphites, but which are in fact carbon-graphites (graphitised) have been devised. This type of material contains a carbon constituent which is not susceptible to graphite transformation. These carbon-graphites tend to have higher hardness and strength, intermediate electrical resistance, thermal layer planes. For extrusions the properties

transverse to the axis of applied pressure are not so favourable as those found in parallel direction. Though not to such a marked degree, the properties of moulded materials in the direction of applied pressure are inferior to those of the transverse orientation.

6. Application considerations for glass forming

Section 4 has outlined the appropriateness of carbon and graphite for glass working tools and Section 5 characterises commercially available materials. In order to use these materials, their

inherent disadvantages must also be understood, together with methods whereby these disadvantages may be offset.

The principal problems depend on the susceptibility of carbon and graphite to oxidation erosion, attrition erosion (wear) and their internal porosity.

6.1 Oxidation

Carbon and graphite are reactive with all gases containing free oxygen, this becomes significant at about 350°C. They also react at various temperatures with gases and vapours having bound oxygen atoms such as carbon dioxide and water vapour. There are two mechanisms by which the oxidation process proceeds. From 350°C to about 800°C it is chemisorption controlled, this is concerned with the volume of sorbed oxidants corresponding to the porosity and the absorbed oxidants on the geometric surface of the pores. In excess of 800°C, it is diffusion controlled, that is related to the velocity of the oxidants over the surface of the material.

Ideally carbon and graphite should be used in a non-oxidising atmosphere, experience has shown that oxidation reactivity may be negligible in atmospheres containing less than 10 ppm. oxygen, 30-40 ppm. carbon dioxide, and where the dewpoint is less than -40°C.

Unfortunately only in special circumstances can glass be worked under these conditions. Therefore a different approach must be made to reduce oxidation rates.

An obvious method is to reduce the accessible porosity, by a densification process, in which carbon is formed within the pore network, thereby reducing both the volume of the pores accessible to oxidising media, and the pore surfaces available for chemisorption.

It is also well known that metallic impurities increase the oxidation rate by catalysis. Experiment shows that a high purity graphite contaminated with 6 ppm. impurities from the ash of a commercial material increased the oxidation rate ratio by 45 times. Purification processes require very high temperatures, therefore graphite only may be purified.

The oxidation rate may also be appreciably reduced by impregnating both

carbons and graphites with inhibitors, which after re-kilning reduces the number of active sites. This form of protection is adequate up to 1,000°C until thermal cycling volatilises or decomposes the complex, the rate then increases to that normal for the material.

These refinements are treatments additional to commercial plain materials, and their use therefore depends upon the economics in terms of increase in useful life.

6.2 Wear

Wear may be considered to be an effect of friction, associated with conditions existing between a "slider" and a counterface. In conventional fluid systems, the persistence of a continuous film between the slider and the counterface is relied upon to reduce frictional forces to a minimum.

At glass working temperatures where the softened or liquid glass is the "slider" and the surface of the former or shaping tool is the countersurface, unbroken conventional films cannot exist.

The current thought on frictional behaviour where no interfacial film exists, is that it may be attributed to the contact of a multitude of asperities between two moving surfaces. Under the influence of local temperature and pressure the asperities become plastically deformed, forming junctions which must be sheared. The weld behaviour and shear strengths of the asperities and junctions are determined by material hardness and solubility between the "slider" and the counterface. The magnitude of the asperities and the debris released by the process both contribute to wear, either by transfer from one surface to another, or, if loose, by a ploughing movement between the sliding surfaces.

Therefore forming or shaping tool materials as previously mentioned must not chemically react with the glass and must avoid welding or sticking. Carbon and graphite in addition to fulfilling these requirements, have an unusual slider/countersurface behaviour. Relative movement such as is found with softened glass moving over the surface of the former tends to disturb the layer lattice structure of the crystallites, shearing them at right

angles to the initially applied load. The graphite platelets divide and are re-distributed at a slight angle to normal on the counterface becoming strongly adherent as a result of surface active forces, thus forming a solid film. This film absorbs within the lattice layer, contact vapours and gases, which have been shown govern the frictional behaviour. The rate of platelet distribution is influenced by the type of glass, the layer plane orientation and the finish of the contact surface of the former.

Therefore chemical and mechanical wear rates can be minimised by the selection of carbon or graphite having the appropriate layer plane orientation. The finish of the forming tools should give a low surface roughness (preferably about 40 micro inches cla). In order to achieve this finish, it must be appreciated that normal cutting practice by conventional machine tools removes carbon or graphite by a tearing mechanism, which disturbs the substrate of the material, promoting the formation of asperities and loosening the particle bonds to a depth of 0.005 ins. to 0.010 ins. To obtain the most desirable finish, this outer layer should be ground out, thereby eliminating the undesirable surface characteristics and conditioning the carbon surface of the former to obtain favourable frictional behaviour.

6.3 Porosity

For some methods of glass forming, particularly where the steam cushion effect is used, controlled porosity is essential. The gas flow characteristics of the pore system control the interfacial pressure of the steam, maintaining an evenly distributed film, thus avoiding distortion of the blown glass.

In the case where no vapour or lubricant film is required at the interface and the "solid film" condition is relied upon to produce an accurate polish finish to the glass, a fine grained close textured carbon or graphite is essential, preferably one which has been treated to reduce pore size and accessible porosity. Here again selection depends on the economics of the useful life.

While commercially available materials can present some longevity problems, these can be overcome to a large extent by careful assessment

of the interfacial conditions and an appropriately treated material, selected to resist the working conditions promoting loss of dimension and definition of the formers.

7. Some Uses of Graphite in Manufacturing Processes

The glass industry may be said to be composed of four major divisions : (i) container glass, (ii) flat glass, (iii) pressed and blown glass and (iv) glass fibre. It has been estimated that container glass, accounts for 40%, flat glass and its products about 30%, pressed and blown glass accounts for approximately 20% and glass fibre the remainder.

7.1 Container Glass

Glass containers are made by flowing molten glass in a mould with highly automated equipment. Blown glassware is distinguished from glass containers by special purpose requirements. Both are made by blowing, but most glassware is hand crafted, whereas all containers are made by high speed machinery.

"Take-out" devices successfully use carbon facings for tongs and fingers for removing pads for lifting optical glass blanks. A hard carbon/graphite maintains accurate dimensions and sharp edges virtually eliminating "crissling" of the glass in the areas of contact.

Graphite textile facings for pusher arms, which direct the containers through the transport system have a good life and prevent craze and cracking of the glass.

Gob pots, or tubes disposed between the cut-off of the molten glass stream and the gob chute, in which the gob is air chilled, are successfully made of graphite. The particular advantage being the non-wetting properties should a gob "touch" the sides, which otherwise would stop production while the pot was cleared.

7.2 Flat Glass

The flat glass category consists largely of sheet, plate, and rolled glass which can be used as is or fabricated into other products such as safety glass or mirrors. Flat glass is used in windows, doors, shelves, furniture, as a structural material and for vehicle windows.

Graphite blocks can be used as lining tiles for the feeding trough and drawing chamber, to facilitate the movement of the

Continued on page 57

VITREOSIL®

high purity transparent tubing

Vitreosil transparent tubing can be used up to 1050°C. and with some reservations at higher temperatures, is inert to all acids except hydrofluoric and has high transmittance in the U.V. and I.R. spectral regions.

It is supplied in a wide range of diameters and wall thicknesses. Transparent tubing can be machined or fabricated to specification for special applications.



VITREOSIL pure fused quartz and silica

is used throughout industry for research, analytical work and for manufacturing processes at high temperatures, requiring absolute standards of purity.

Full details on request.

VITREOSIL®
THERMAL SYNDICATE LIMITED

P.O. Box No. 6, WALLSEND, NORTHUMBERLAND Tel. Wallsend 625311 Telex 53614
9 BERKELEY STREET, LONDON, W.1 Tel. HYDe Park 1711 Telex 263945

SILICA INDUSTRIAL WARE • LABORATORY WARE • OPTICAL COMPONENTS • HIGH TEMPERATURE OXIDE CERAMICS



Let us supply your

SCIENTIFIC RESEARCH APPARATUS

GLASS Apparatus made to your specification

QUARTZ Worked and supplied. Large stocks held

GLASS TO METAL SEALS One off to one million off. Made to customers specification

SCOTLAND ROAD CAMBRIDGE

Telephone 56190

L . G . M

LABORATORY GLASSWARE MANUFACTURERS LTD

High Vacuum Stopcocks

**STOPCOCKS OF THE VERY HIGHEST QUALITY
INSPECTED AND TESTED INDIVIDUALLY**

REALISTIC DELIVERY TIMES COUPLED WITH COMPETITIVE PRICES

We manufacture

All standard interchangeable ground glass apparatus

We have

Our own calibration and graduation departments, so we are well equipped to provide all kinds of Specials to customers' own specifications

We make

Apparatus in fused quartz, and carry a stock of tubing and interchangeable joints of our own manufacture

We are

LABORATORY GLASSWARE MANUFACTURERS Ltd

200 RAVENSCROFT ROAD · BECKENHAM · KENT

Telephone : SYDENHAM 6593

Send for our Catalogue

ABSTRACTS

Compiled by S. D. FUSSEY

ANALYSIS

(334) Versatile Combination Ozone and Sulphur Dioxide Analyser.

F. Schulze, *Anal. Chem.*, 38, 6, pp. 748-752, May 1966.

Diagram of apparatus and associated electrical circuits with full details of method and results. G.H.

(335) Spectrophotometric Determination of Ruthenium with 1-Nitroso-2-Naphthal.

G. Kesser, R. Meyer and R. Larsen, *Anal. Chem.*, 38, 2, pp. 221-224, Feb. 1966.

Detailed drawing and method applied to determination of 0.005 to 0.1% ruthenium in zinc-magnesium alloys. G.H.

(336) Determination of Oxygen in Niobium Pentachloride by a Bromination Technique.

J. McKay and J. Below, *Anal. Chem.*, 37, 12, pp. 1618-1619, Nov. 1965.

Sketch of complete bromination apparatus together with description of method and tables of results. G.H.

(337) The Determination of Nitrogen in Low-Weight Steel Samples.

B. Bach, R. Wills and R. Reid, *Metallurgia*, 74, 444, Oct. 1966.

A method has been developed which enables one gram samples in the range 0.001 to 0.025% nitrogen to be analysed. The method employs a sensitive colorimetric determination of the ammonia released after Kjeldahl distillation of the sample solutions. Diagram of glass apparatus. S.D.F.

CATHODES

(338) Osmium Dispenser Cathodes

P. Zalm and A. van Stratum, *Philips Tech. Rev.*, 27, 3/4, p. 69, 1966.

Promising results have been achieved in the development of dispenser cathodes using the less common metals—in this case osmium. D.A.H.

CHROMATOGRAPHY

(339) Improved Sulphur-Reacting Microcoulometric Cell for Gas Chromatography.

D. Adams, G. Jenson, P. Steadman, R. Koppe and T. Robertson, *Anal. Chem.*, 38, 8, pp. 1094-1096, July 1966.

Fully dimensional illustration of apparatus and results obtained. G.H.

(340) A Sprayer for Chromatographic use.

R. Bailey, *Chem. Anal.*, 55, 2, p. 56, April 1966.

A sturdy and compact sprayer capable of vaporising 55 ml. of water at 36lbs. per sq. inch. Fully dimensioned drawing. D.A.H.

DEWARs

(341) Dewar for use in Crystal Raman Spectroscopy.

A. Gee and D. O'Shea, *Rev. Sci. Instru.*, 37, 5, pp. 670-671, May 1966.

A "Pyrex" dewar with optical windows in the tip. The crystal is flushed with nitrogen evaporating in the dewar, which not only cools it but also prevents moisture condensing on it. S.D.F.

DILATOMETER

(342) Low Cost, Automatic Quartz Dilatometer.

P. Wagner, A. Gonzales, R. Miner and P. Armstrong, *Rev. Sci. Instru.*, 37, 2, pp. 180-182, Feb. 1966.

A fully automatic fused quartz dilatometer for operation in the temperature interval 25-700°C has been designed and built. Use of an unbonded strain gauge as the measurement transducer has resulted in a system of great simplicity, high precision and very low cost. Details of design and operation are discussed. S.D.F.

EDUCATION

(343) What the Creative Man Demands of Management.

G. Whittington, *R. and D.*, 17, 8, pp. 19-22, August 1966.

The truly creative individual is not a different human being, but he does develop a personality which sets him apart. To provide a basis for a satisfactory and productive working relationship with the creative individual, his personal attributes should be well understood by the R. and D. manager, for, while his demands on management are those of any other employee, they are harder to satisfy—yet must be met. S.D.F.

FLOW-CONTROL

(344) Convenient Safety Cut-off Device for Water-Cooled Equipment.

J. Ritter and T. Coyle, *Rev. Sci. Instru.*, 37, 4, p. 523, April 1966.

Description of a simple sensor and control circuit for protecting water-cooled equipment. S.D.F.

(345) Simple Flow Switch.

M. Reiman, *Rev. Sci. Instru.*, 37, 5, p. 681, May 1966.

A quickly assembled pressure differential flow switch. Useful as a fail safe current breaker for water-cooled devices. S.D.F.

GAS—HANDLING

(346) A Device for Filling Hypodermic Syringes with Small Quantities of Nitrogen Dioxide Gas.

H. Pierrard and J. Lodge, *Chem. Anal.*, 43, 8, p. 55, April 1966.

A device which enables a small quantity of nitrogen dioxide gas to be removed from a cylinder without corrosive problems. Illustration. D.A.H.

GLASS

(347) High Strength Glass Materials.

P. McMillan, *The Engineer*, 222, 5771, 351-352, Sept. 1966.

No. 3 of a series "Materials for Engineers", this article gives a brief explanation of why glass is weaker than the calculated theoretical strength, followed by a description of methods of strengthening. Materials, processes, properties and design considerations are given for glass ceramics and surface crystallised glasses. S.D.F.

GLASSWORKING—TOOLS

(348) New Techniques in Finishing Glassware.

T. Marles, *Indust. Dia. Rev.*, 26, 305, pp. 140-143, April 1966.

A diamond saw bench introduced to replace the traditional cracking-off and grinding of blown glassware. W.V.B.

(349) Art and Industrial Diamonds.

T. Trancu, *Indust. Dia. Rev.*, 26, 311, pp. 456-457, Oct. 1966.

Master craftsmen in Milan use various diamond tools to finish artistic interior fittings and crystal objects, bringing out the intrinsic beauty of the raw materials to the full. W.V.B.

OSMOSIS

(350) Electro-Osmosis as a Demonstration Experiment.

Dixon and Schafer, *Journ. of Chem. Educ.*, 43, 7, p. 381, July 1966.

Phenomenon of electro-osmosis demonstrated with a simple apparatus consisting of a tube with sintered disc and silver electrode. F.G.P.

PIPETTES

(351) **Semi-automatic Precision Pipette.**
E. Eckfeldt and E. Schaffer, jun., *Anal. Chem.* 37, 12, pp. 1624-1626, Nov. 1965.
Drawing of precision pipette and table showing precision obtained by two different methods. G.H.

SAFETY

(352) **Handling Perchloric Acid.**
C. Wirth, *Lab. Practice*, 15, 6, 675, June 1966.
Details of 72% and Anhydrous Perchloric Acid. Safety differences are explained. B.R.W.

(353) **Prevention of Implosion of Dewar Flasks.**
A.I.K., *Chem. Anal.*, 55, 2, p. 62, April 1966.
When a solid carbon dioxide-solvent mixture is used to cool a glass trap, the latter may "freeze" to the sides or bottom of the Dewar flask. Application of a coating of a commercial aerosol silicone spray to the sides and bottom of the glass trap has been found to prevent such freezing thereby allowing safe and easy removal of Dewar flasks. D.A.H.

STIRRING

(354) **Magnetic Stirring for Glass Pressure Reactors.**
Patton and Johnson, *Journ. of Chem. Educ.*, 43, 7, p. 391, July 1966.
Describes "Magna Dash" magnetic stirring device used when agitation is required during reactions in high pressure experiments. Gives circuit for driving solenoid. F.G.P.

TITRATION

(355) **Precise Standardization by Coulometric Titration using Simplified Equipment.**
E. Eckfeldt and E. Schaffer, *Anal. Chem.*, 37, 12, pp. 1534-1540, Nov. 1965.
Scale drawing of special cell with counter flow separations; also block diagrams of electrical circuits. Eighteen references. G.H.

(356) **Simple Equipment for Automatic Potentiometric pH Titrations.**
Eugene Olsen, *Journ. of Chem. Educ.*, 43, 6, p. 311, June 1966.
Description and illustration of apparatus for automatic delivery of titrant solution. F.G.P.

THIN FILMS

(357) **A Vacuum Magnetometer for Studying Ferromagnetic Films.**
R. Telesnin, E. Ryback and I. Saraeva, *Journ. of Instr. and Exper. Tech., U.S.S.R.*, 3, p. 719, Pub. trans. Dec. 1965.
This device can deposit films, carry out thermomagnetic processing, measure constants of magnetic anisotropy in vacuum and determine saturation magnetization and coercive force of films. D.A.H.

(358) **Microfractography of Thin Films.**
J. Nieuwenhuizen and H. Haanstra, *Philips Tech. Rev.*, 27, 3/4, p. 87, 1966.
An insight into the structure of thin films has been obtained by using an electron microscope for examining aluminium films of 1 micron thickness. Good photographs are shown. D.A.H.

VACUUM-GAUGES

(359) **The Problems of Ultra-high Vacuum Measurements.**
P. Yeager, *R. and D.*, 17, 10, pp. 63-67, Oct. 1966.
Although sensitivity of U.H.V. gauges has advanced greatly in the last few years, it has not kept pace with the capabilities of systems. Readings from presently available gauges are in considerable error at 10^{-10} Torr and even less reliable in the 10^{-11} Torr range. S.D.F.

VACUUM GAUGES, CALIBRATION

(360) **Traceable Vacuum-Gauge Calibration by Incremental Mass Addition.**
M. Bottroff and R. Chuan, *R. and D.*, 17, 8, pp. 60-63, Aug. 1966.

A calibration system in which a precisely controlled amount of gas is added to an initially evacuated reference volume, is applicable to high-vacuum region and can be used with any gas or gas mixture. S.D.F.

VACUUM—SEALS

(361) **Simple Method of Preparing Direct Glass Metal Seals.**

M. Novack and G. Dionne, *Rev. Sci. Instr.*, 37, 3, pp. 378-379, March 1966.
Full description of a simple bench method of making oxide-free wire seals for high vacuum use, capable of withstanding attack by hot alkali vapours such as caesium. S.D.F.

(362) **Method of Sealing Electrical Leads in Low-Temperature Dewars.**

C. Blount, *Rev. Sci. Instr.*, 37, 3, p. 376, March 1966.
Wires pushed through undersized holes in "O" ring make vacuum tight electrical lead throughs. Undesirable junctions between differing wires may be avoided by such seals. S.D.F.

VACUUM—VALVES

(363) **A Greaseless Vacuum Valve.**
Hooker and Spencer, *J. Sci. Instrum.*, 43, 5, p. 339, May, 1966.
A glass, stainless steel and mercury valve used to regulate gases, vapours and liquids at atmospheric pressure or below into evacuated systems. Can replace convention mercury cut-offs. Diagram. D.A.H.

(364) **Mercury Actuated Vacuum Valve with Magnetic Release.**
E. Haran, *Rev. Sci. Instr.*, 37, 4, pp. 523-524, April 1966.
Description of glass apparatus and electrical control circuit. Pool of mercury brakes movement of floats thus eliminating glass breakage and permitting pulsed solenoid excitation. S.D.F.

MISCELLANEOUS APPARATUS

(365) **Improved Victor Veyer Apparatus.**
M. Eader, *Journ. of Chem. Educ.*, 43, 9, p. 501, Sept. 1966.
Apparatus has "spike" breaker in inner tube onto which sample bulb is dropped, thus ensuring ampoule breaks every time. F.G.P.

(366) **Simple Vacuum Cooled Ozonizer.**
V. Dardin, *Journ. of Chem. Educ.*, 43, 8, p. 439, Aug. 1966.
Complete description of apparatus and method of use. F.G.P.

(367) **Evaporation Manifold for Septum Sealed Vials.**
G. Litt and N. Adler, *Anal. Chem.*, 38, 8, pp. 1096-1097, July 1966.
Description of method and photograph of evaporation manifold. G.H.

(368) **Counter Double Current Distribution with Continuous Recovery for Isolation of Methyl Linolate.**
R. Butterfield, H. Dutton and C. Scholfield, *Anal. Chem.*, 38, 1, pp. 86-88, Jan. 1966.

Full details of method, results tables and sketch of apparatus. G.H.
(369) **Micro Apparatus for Demonstrating Electrophoresis and Ion Migration.**
Stock and De Thomas, *Journ. of Chem. Educ.*, 43, 8, p. 437, Aug. 1966.

A simple "U" tube with electrodes and a solution of Ferric Hydroxide and Arsenious Sulphide are used to show change of boundaries. F.G.P.

STOPCOCKS complete range by SPRINGHAM

HIGH VACUUM Hollow Key

Pyrex Glass, precision ground. Each INDIVIDUALLY TESTED and GUARANTEED. Early delivery



P.T.F.E. (FLUON) Greaseless

For use with liquids requiring no Grease. Essential for Acids, Alkalies, Caustic Soda, Solvents, Hydrocarbons and Gas Chromatography. Fully interchangeable with INTERKEY range of Stopcocks and Apparatus

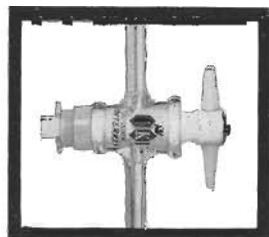

Spring Loaded

Improved type giving variable tension. Parts of nickel-plated brass with stainless steel springs

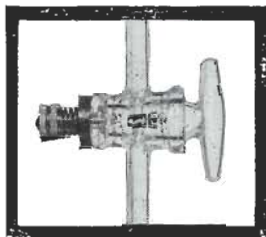

MICRO CONTROL p.f.f.e. (Fluon)

For use with liquids at less than 1 drop per second. No grease and also fully interchangeable with INTERKEY range of Stopcocks and Apparatus

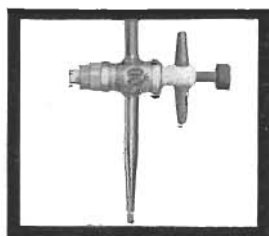

HIGH VACUUM Greaseless

Using VITON "A" or NEOPRENE diaphragm with Pyrex glass body, giving fine control and performance of 10-6 or better at -60° to 450°F.

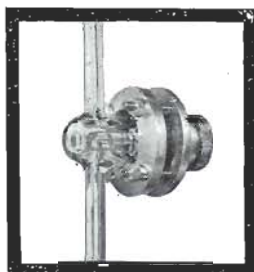

Sizes 1 mm to 10 mm bore — all parts interchangeable

**General Purpose Solid Key — INTERKEY
Interchangeable
Keys**

All sizes 1 mm to 8 mm bore. Straight pattern, Single oblique, Double oblique, "T" and "Y" bores

- No Leakage
- Early Delivery
- Spare Keys
- Immediate Key replacement



Descriptive literature and price lists available from

G. SPRINGHAM & CO LTD HARLOW NEW TOWN, ESSEX • HARLOW 24108

NEW!! first time available **SOLID KEY**

. . . High Vacuum Stopcocks . . .

developed from INTERKEY "perfect taper" techniques

- Guaranteed Hollow Key performance
- All types and sizes to 6 mm bore
- Early delivery
- Each key and barrel precision hand-lapped and permanently numbered
- 20/25 per cent advantage over Hollow Key counterpart

New catalogue with full details :

G. SPRINGHAM & CO LTD

HARLOW - ESSEX

For all your **GLASS CUTTING, REAMING, GRINDING** or **DRILLING** problems consult

F. Yorke & Partners Ltd

Highbridge Wharf
Eastney Street
Greenwich, S.E.10

Telephone : GRE 6215-6

who are the sole agents in the U.K. for **DIAMANT BOART S.A.**, Brussels
Europe's leading Diamond Tool Manufacturers

"One picture is worth 1000 words"

No picture here

because no one picture could ever represent the 1000 (and many more) ovens and furnaces we have made for glassblowers in the last 40 years

annealing

We make electric furnaces and ovens for laboratory work, research and all production processes—200°C to 1750°C

furnaces ovens kilns lehrs

to suit your own particular requirements

Some standard sizes but 80% are built to "special" shapes, styles, sizes to suit individual requirements—but at attractive prices and good deliveries. With or without fans, switchgear, instruments. Have your job tailored by the specialists

catterson-smith

R. M. CATTERSON-SMITH LTD. (Dept. SG), Exhibition Grounds
WEMBLEY

Telephone

WEMbley 4291

Continued from page 56

viscous glass. Drawing and forming rolls may be either wholly graphite or in the form of a shroud over a metal roll. In some processes the glass is cast on to a table surfaced with graphite slabs prior to rolling. In the majority of cases the large size and area of fine grained close textured graphites required are commercially unavailable, so comparatively coarse textured grades have to be tolerated.

The most significant breakthrough in recent years in the manufacture of flat glass is the Pilkington float process in which a number of carbon or graphite components are used. This process has the singular advantage of operating in a non-oxidising atmosphere and therefore has a profound effect on the useful life of the carbon and graphite parts.

7.3 Pressed and Blown Glass

Pressed glass is glass formed by using a plunger to press a charge of hot plastic glass in a metal mould; blown glass is formed by using compressed air to force molten glass against the inside of a mould. Both glass forms have a wide variety of application, the former includes table ware, kitchen ware and novelty products. Metal mould sets are almost exclusively used for this type of operation as commercial carbons and graphites do not have the strength or erosion resistant properties to withstand the arduous conditions imposed by high speed mass production methods. However, with the development of high strength carbons and graphites and the gradual acceptance of the industry of controlled atmosphere conditions, it is possible in the foreseeable future that carbon materials can usefully be substituted.

The latter method (blown glass) has applications for household ware (drinking glass, lamp shades, etc.), glass electronic products, envelopes for lighting appliances (bulbs, etc.), scientific laboratory glassware and technical glassware. For the majority of these operations carbon and graphite can be and is usefully employed for the blowing moulds and forming operations.

7.3.1 Blowing Operations

Cast iron moulds faced with cork powder and wood dust can be replaced by a book mould cut from porous car-

bon. As already mentioned the principle employed is to form the hollow shape against a cushion of steam, created by the contact of viscous glass against a body, the pore system of which contains water.

The cork type facing being relatively thin can hold only a limited amount of water the excess steam being removed by a simple system of venting. However, for the wholly carbon mould on strength considerations alone the bulk of the material used must be considerably greater. The amount of water held in the pore system can thus be comparatively large. It becomes necessary therefore to provide for the rapid egress of much larger volumes of steam, achieved by increasing the number of vents strategically placed in the joint faces of the closed book, and arranging for the outer surface of the mould to be free from any housing or support likely to restrain the flow of steam.

This may conveniently be done by using a hinged housing constructed in sheet metal, the carbon mould being held in position by shouldered studs (or similar) leaving an annular air gap between the outer surface of the mould and the sheet metal housing.

7.3.2. Forming Operations

For work of this type and for reasons previously detailed a fine grained close textured carbon or graphite is necessary. Many shapes of forming tools are used, but some idea of the scope of the applications may be seen by again referring to Fig. 2. BS572 describes standard cone and socket former for ground glass joints. Fig. 4 illustrates some examples of these formers. Centrifugal forming tools used in an automatic set-up are shown in Fig. 5.

The starting form for many applications such as strip lighting envelopes, medical and scientific glassware is tube stock. In the first case the tube is made by the Vello process, in which the cast is fed downwards through an annular orifice to a horizontal drawback. Carbon and graphite diabolos (rollers having a peripheral V groove) transport the tube through the Vello line. An

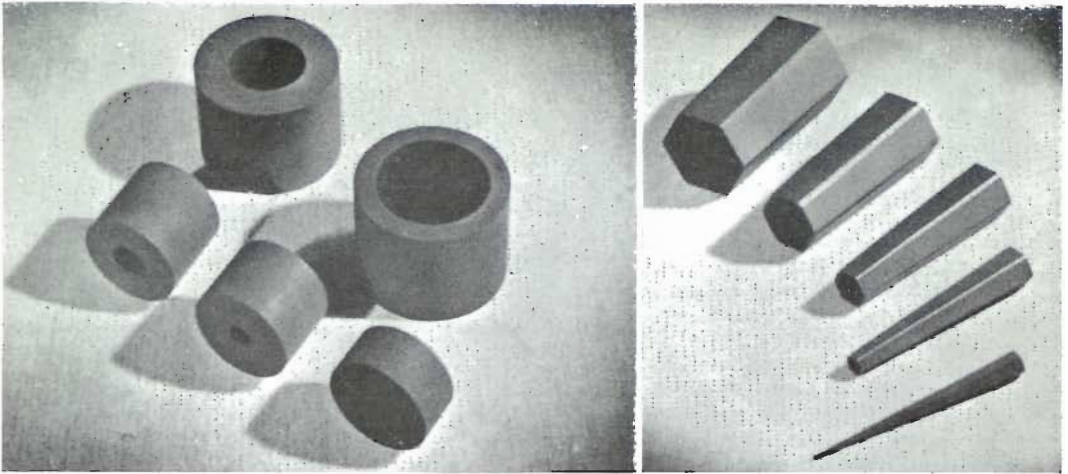

FIGURE 4 Typical socket and cone formers manufactured by Morganite Carbon Ltd. to B.S. 572.

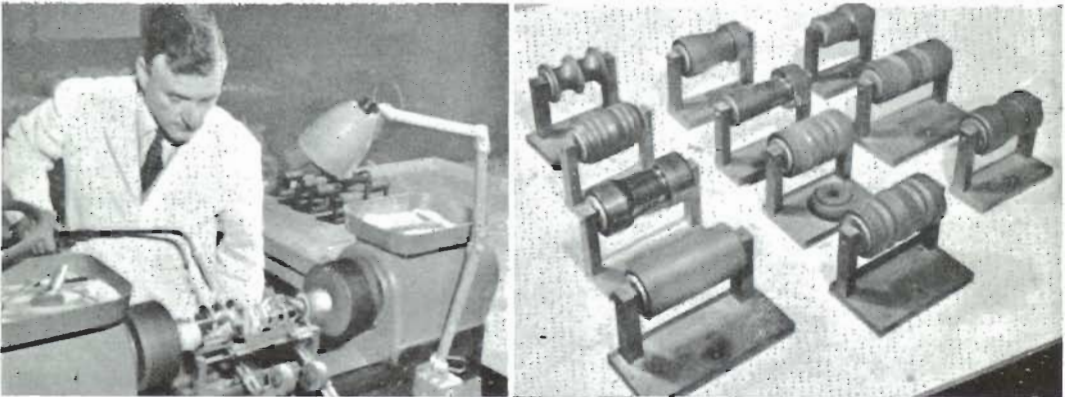

FIGURE 5 The new technique of centrifugal forming. Glass tubing is rotated at high speed in a special lathe. When the glass softens under the blowpipe, it is thrown outwards against the carbon former to produce the desired shape. A selection of carbon formers is shown on the right. *Reproduced by courtesy of Baird and Tatlock Ltd.*

example of medical ware in the manufacture of ampoules (highly mechanised process), here again transport rollers are in carbon or graphite as are the lip and base forming anvils. Much scientific ware is used for measuring purposes, requiring accurately reproducible bore dimensions. This precision bore tubing is sized by drawing

the softened glass over a carbon mandrel having a tapered lead.

The first characteristic of carbon and graphite to be considered for all the applications in this section is the orientation of the layer planes (discussed in Sections 5 and 6.2). To obtain the best performance from a former, the planes should be parallel to the

movement of the forming operation. For example, the external forming roller used in joining the stem to a cathode ray tube, made from a press formed carbon blank (layer planes perpendicular to the forming movement) had a life of four to five hours. When this was made from an extruded material (layer planes parallel to the forming movement) the

useful life increased five-fold. In addition when the roller was treated with an oxidation inhibitor (Section 6.1) a further five-fold increase in life was experienced.

7.3.3 Glass to Metal Sealing Operations

This is essentially a sintering process, whereby glass powder in contact with metal components are heat treated in a



FIGURE 6

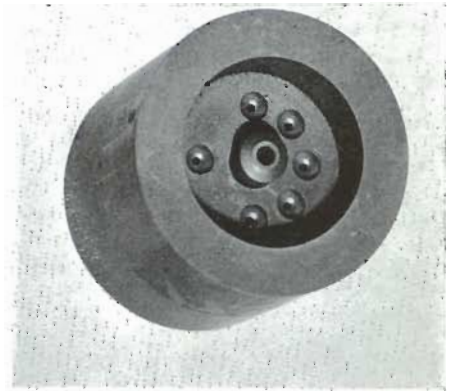

FIGURE 7

non-oxidising atmosphere causing the particles to cohere, forming an impermeable body jointed to the metal.

The best known applications are the manufacture of thermionic valve bases and the glassing of transistor and diode assemblies. In the first, two or three part carbon or graphite moulds are used, as illustrated in Fig. 6. In the second instance the jigs used for the positioning of semi-conductor components are in densified close texture and purified graphites, some typical configurations are shown in Fig. 7.

7.4 Glass fibre is made by attenuating molten glass by drawing individual filaments through a small diameter orifice, followed by a stranding process to produce a glass yarn, which in turn may be woven to a glass cloth. Carbon has been used for a spinneret type device for producing the filaments and for pads used in the stranding process.

8. Conclusion

It may be seen that the applications of carbon and graphite in the glass industry are wide and varied. The selection of suitable materials is related to the system in contact, porous materials being necessary for mould blowing against a steam cushion, materials with a small accessible porosity of a preferred layer plane orientation for forming tools.

The dividing line between the choice of carbons and graphites for glass formers is related to the softening temperature of the glass to be worked. As this temperature increases, so does the oxidation erosion rate of carbons, to the point where the lower oxidation erosion rate of graphite counterbalances the latter's rather greater attrition rates.

The following table compares hardness and oxidation rates for various families of materials, and shows the improvement in these critical characteristics when commercial base grades are treated with oxidation inhibitors and densified to reduce accessible porosity.

	<i>Hardness</i>	<i>% Porosity</i>	<i>Wt. Loss % Hr. Oxidation Rate</i>
Extruded	55		at 600°C
Carbon CY9	55	14	4.5
Graphite EY9	45	17	0.8
Moulded			at 600°C
Carbon CY9106	90	13	1.7
Graphite EY 9106	50	14	1.1
Effect of Purification			at 600°C
Graphite EYC9106	50	14	0.15
Moulded			at 550°C
Effect of reduction in porosity and purification			
Graphite TYXC14	60	6	0.109
Effect of reduction in porosity and inhibition			
Graphite TYX22	60	6	0.037
Effect of reduction in porosity, purification and inhibition			
Graphite TYX39	60	6	0.027

LEEDS COLLOQUIUM, 24th September, 1966

FULL reports not yet being available, this brief account will give some idea of the atmosphere prevailing at the Metropole Hotel.

Members from various parts of the country began to arrive early on Friday evening and were met in the hotel foyer by Rex Eustance and Harry Butler, who gave a quick briefing on the hotel's amenities, which was a great help in enabling us all to settle in quickly.

Supper was available, after which some members went out to explore the town; others remaining were joined by members of the North Eastern Section, and discussions on glassworking and the Society went on well into the night, when it was ultimately decided to get some sleep.

After breakfast on Saturday morning the real activity commenced, the lecture room was got ready and exhibitors erected their displays in the adjoining room.

More members arrived, and coffee was served as a preliminary to the talks.

The first talk on the "History of Glassblowing in England" was given by Mr. J. H. Burrow and, although given from a personal angle, it was obvious that the memories of many older members had been roused, and after the lecture many common experiences were discussed.

Lunch was then served in the banqueting room and the hotel staff worked hard in catering for over 100 guests.

After lunch there was some time to look at the exhibits and then to drift back into the lecture room, where the first talk of the afternoon was given by Mr. F. Sedgewick of James A. Jobling, and in the short time available he gave a comprehensive account, illustrated by many first-class slides, of the structure and composition of glass, its manufacture and methods of forming it.

He was followed by Mr. N. Payne of I.C.I. Ltd., Plastics Division, who gave a speculative talk on how the future of the glassblower is likely to be affected by new materials and methods of working and also as a result of changes in research and requirements.

Tea was then served and half an hour was spent on questions, after which the Chairman, Mr. E. G. Evans, gave an account of his experiences during his visit to the American Scientific Glassblowers Society, 1966, Symposium.

Finally, the Jobling Award and Woods trophy were presented.

As an experiment in running a colloquium to fully use the time and space available and in addition to give the maximum comfort to those attending, the colloquium was an undoubted success, reflecting the spirit existing in the N.E. Section, and a new standard has been set for future years.

The Society thanks all those who were involved in its organisation.

CHAIRMAN'S AMERICAN VISIT

AS you are all aware, I attended the American Symposium held in Boston this year. I went along as your Ambassador and to present a paper and give demonstrations on a subject which is considered to have a great potential.

On my arrival I was met and taken to my hotel by the Symposium Chairman, Mr. Tony Velluto.

My first meeting was an all-day business meeting at which I conveyed a message on behalf of the B.S.S.G. and gave an account of our Society and its ways of operation.

I attended a Board of Directors meeting on the second day and was invited to speak on our education policy; this I broadly outlined and gave a description of our examination procedure. Great interest was shown.

The Symposium proper began on the third day. I presented my paper on "Centrifuging Glass Tubing," which was received with terrific

enthusiasm and everybody was impressed. In the afternoon I gave two half-hour demonstrations which left no doubt as to the efficiency of this technique. I attended all the lectures at the Symposium and gave further demonstrations on the remaining days.

The A.G.M. of the American Society was held during the Symposium week. I was invited to speak as a guest.

After the Symposium I visited the establishments of Corning, Kontes, Kimble, Frederick & Dimmock, Ace Glass, Lydon Bros., Fisher and Porter groups and the Glass Corporation of Anchor Hocking, which took me to New York, Corning City, Vineland, New Jersey and Philadelphia.

Sincere thanks must go to William Wilt of Wilt Glassblowing Incorporated, for taking me on a complete tour of the places I have mentioned and for looking after me during this time.

Thanks must also be conveyed to his wife, Peggy, who graciously took me into their summer home for a memorable week-end that I shall never forget.

On leaving the A.S.G.S. I was asked to convey the following message :—

“ We thank the B.S.S.G. and its Chairman who represented you for representation at our Symposium. It has been an honour for us to receive your Ambassador and to listen to and take account of the ways and means of your Society. We look forward with great interest to the results of your examination policy for full membership. We would welcome affiliation of some nature ; this will be discussed at our next business meet-

ing ; our findings will be forwarded to you. We wish your Symposium every success, and hope that in future years we may participate in some way.”

I feel that I have fulfilled at least one of the aims of our Society by presenting my paper at their Symposium. I can confidently predict that my visit has done much to secure a greater understanding between the two countries and has brought about a better relationship with regard to passing on of techniques and ideas, promoted affiliations, and has also furthered the knowledge of a great number of glassblowers and other members of this complex community.

E. G. EVANS
2nd September, 1966

JOBLING CUP AWARD

THE first award of the Jobling Cup, donated by James A. Jobling, the “ Pyrex ” manufacturers, for the outstanding student member of the British Society of Scientific Glassblowers, has been made to Mr. Eric Collin Wigget, aged 20, of Blackley, Manchester, an apprentice in the I.C.I. Dyestuffs Division. The cup was presented

by Mr. H. J. Johnston, the home sales manager of Jobling's laboratory apparatus division.

Mr. Wigget submitted a multi-surface spherical condenser as an example of his handiwork.

Photographs of the cup presentation and trade stands are available from Heaney & Mill, 50 Otley Road, Leeds 6.

NITROGEN DIOXIDE AND SILICA WORKING

AFTER prolonged periods of silica working on large-diameter tubes, operators were found to be suffering from effects of what at first was thought to be heat, but after careful investigation turned out to be something very different.

During the working, there appeared dark red fumes in the tube and they gave off a smell of nitric acid. Samples were tested and proved to be oxides of nitrogen formed by the burning of air at temperatures of 2000°C and above, but the most important find was that nitrogen dioxide was present in many parts per million, not only in the tubes but in the surrounding atmosphere, and was being breathed in via the blowing tube and normal breathing.

Action was immediately taken ; better extraction took care of the atmosphere, but the problem was the blowing. Experience has proved that more control is exercised by mouth-blowing as against the use of compressed air or gas, so experiments were made to find the best way of preventing the operator from breathing the deadly fumes of nitrogen dioxide.

A method was found and put into use and after two years no ill effects have been noticed.

I enclose a drawing of an absorber that is in constant use and has given complete protection.

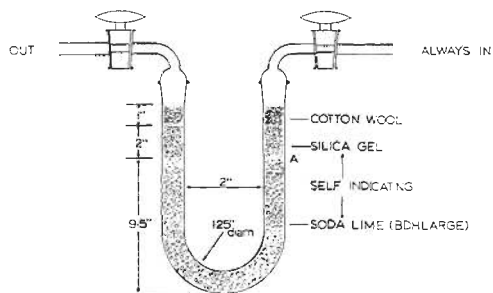

Nitrogen Dioxide Absorber

The life of the absorber for every day use is approximately 100 hours per charge.

When to re-charge can be seen by the change in colour of the soda lime which turns yellow; where it comes in contact with the silica gel. The whole contents of the absorber must then be discarded and filled with a fresh charge.

J. G. BRETT
8th September, 1966

SECTION ACTIVITIES

Midland Section

Visit to A.E.I. Lamps and Lighting at Melton Road, Leicester, and to the Central Research Laboratory, Rugby, 20th September, 1966

A party of 20 members of the section assembled for coffee at Melton Road, after which they were conducted on a tour of the factory, seeing machines winding filaments, the automatic assembly of filament mountings, and the assembly of lamp bulbs from pigmy at one end of the range to 1kw gas-filled bulbs at the other, and in addition the manufacture of special types such as sodium and mercury discharge lamps. Our members were impressed by the automation of the intricate and delicate operations involved in the production of these bulbs and came away with a greater respect of the problems involved in the manufacture of these A.E.I. products.

A cavalcade of cars then went through Leicester to the Airman's Rest for lunch and then on to the Central Research Laboratories at Rugby. There we were met by the Information Officer, who outlined the work done at the laboratories and then introduced us to our guides who then escorted us to the Analytical Services Group Laboratories where the techniques of radiochemical, chemical, X-ray, microprobe, mass spectrometry, emission spectrometry, and gas analysis were outlined. The use of each of these techniques in solving a particular analytical problem was described. Particular emphasis was made of gas analysis problems related to the investigation of very small quantities of gas trapped in bubbles in glass, gas fillings in various lamps, and the desorption and diffusion of gases from silica.

We then visited the section where specialised lamps are developed. Examples are as follows:

A 400w. high-pressure sodium vapour discharge lamp of high efficiency and good colour. The arc tube is of "Stelox," a translucent alumina ceramic manufactured by B.L.I.

A 2-4kw. high-pressure water-cooled mercury lamp in fused silica, developed for laser pumping with a very high output in the u.v. region.

High-pressure water-cooled Krypton lamp. This lamp, rated at 2-3kw. was also developed for laser pumping and has heavy current, cylindrical type molybdenum foil seals.

The visit continued at a crystal-growing laboratory where a talk was given on the growing of single crystals from the melt. The

materials, mainly oxides and mixed oxides such as Lithium Niobate, calcium tungstate and yttrium aluminium garnet, had melting points between 1250°C and 1950°C and were melted in iridium or platinum crucibles. The power to melt was supplied by an R.F. generator, the crucible being supported by refractory and enclosed in a silica jacket which was filled with inert gas, the R.F. coil being on the outside. The seed crystal having been dipped in the melt, was slowly withdrawn at rates from $\frac{1}{2}$ in. to 1/20th in. per hour depending on the material, until a crystal over 2in. long was grown. Some crystals were neodymium doped and are used to make laser rods 2in. long by $\frac{1}{4}$ in. diameter. These must be optically perfect, which requires strict control of all the growth parameters.

With the high melting point and slow growing materials, the deterioration of the silica jacket, which had a side viewing arm, was rapid, sometimes lasting for only one run. The glass-blowing section of the laboratory maintains a constant supply of these silica Y tubes.

A film was then shown of the construction of a Glass Toroid for a 20 MeV. Betatron, in which our members from A.E.I., Mr. W. V. Baker and his assistants, were seen applying their skill to this difficult exercise of the glassworking craft.

Finally, there was an invitation to wander at will into the glassworking section of the research laboratory, to ask as many questions as we pleased and to see what "Bill" and his colleagues did. We thank Associated Electrical Industries and Mr. Baker for a most interesting day.

J. W. COOKSON

North-Western Section

Twenty-four members visited the works of James A. Jobling Ltd. on the 7th September, 1966, which involved a round trip of several hundred miles. Nevertheless, the effort was amply repaid. The party was met at the Roker Hotel by the management and entertained to lunch, after which they proceeded to Wear Glass Works and were conducted around the factory in several small parties. Many manufacturing processes were seen, from the actual glassmaking, through hand-blowing of flasks and machine-blowing operations, to pressing processes for the manufacture of plates and other domestic ware.

The highlight of this part of the tour was the hand-making of a 200-litre flask to be used by Q.V.F. Ltd. A visit to the benchworking section then followed where Oldershaw columns,

stopcocks and joints and other pieces of glass equipment were being made. Following these processes such as graduation, decoration of domestic ware, and the making of precision bore tube were seen, together with many other techniques: in all, an intensive concentration of methods of glass manufacture limited only by the time available.

At the completion of the tour, tea and biscuits were served in the Board Room, and it was obvious throughout that Messrs. Jobling's are very much alive to the needs of the glass-blower and support him in every possible way.

We thank them for a most interesting visit, carried out in excellent weather.

On the 13th October members of the section visited the works of Plowden & Thompson and Messrs. Stuart & Sons at Stourbridge. As is usual, members enjoyed the well-known hospitality of these firms, which has previously been described in the Journal.

On the 16th September a section business meeting was carried out at which a formal vote of thanks to Messrs. Jobling was recorded, and discussions took place regarding other visits and lecturers.

An interesting and informative talk on Quartz working was given by Mr. Burgess of Ferranit Bros., Wythenshawe, following discussions on other future visits and lectures.

On the 21st October Mr. W. V. Baker of A.E.I. Research Laboratories gave a very interesting lecture on metal glass seals. He described copper to glass, and Kovar to glass seals in such complete detail for the benefit of those knowing little of the subject, that the lecture lasted the entire evening and the informal discussions which followed prevented the scheduled business meeting being properly carried out.

Thames Valley Section

The 1966-67 season of this section's activities began with a trip to Stone, Staffs., to visit the works of Messrs. Quickfit & Quartz, where impressive demonstrations were seen of semi-mass production methods of glassblowing.

Thanks are given to the firm for their hospitality.

A meeting of the Colloquium committee took place on the 12th September, at which possible subjects were discussed. There were many ideas but more are needed before final selection is made, it being the intention to make the 1967 Colloquium an outstanding event.

1966-67 PROGRAMME

All meetings will be held in the new Chemistry Department of Reading University at Whiteknights Park.

14th September

Visit to Quickfit and Quartz—arrive at 1.00 p.m. for lunch.

6th October, 6.30 p.m.

"Xenon Flash Tubes"—Dr. R. Rout. Dr. Rout is a physicist carrying out research into high energy laser systems; one aspect of his work is developing powerful flash tubes.

5th January, 6.00 p.m.

Section A.G.M.

6.30 p.m. "Optics and Cameras"—Mr. R. Brown. Bernard Brown, a graduate of London University, is at present engaged by the Optical Division of Atomic Weapons Research Establishment. There he is working on the development of high-speed camera systems, optical instrumentation and ultra-violet lens systems.

2nd February, 6.30 p.m.

"Glassworking machines"—Mr. Thomas. Mr. Thomas is a Technical Director of L. Richoux & Co. Ltd., the well-known firm of glass-working machinery importers; Mr. Thomas has several interesting films in his programme.

2nd March, 6.30 p.m.

"High Power Gas Lasers"—D. Hunt. David Hunt joined the Atomic Energy Authority to work on controlled thermo-nuclear reactions, upper atmosphere detection systems and high power ruby and gas lasers.

6th April, 6.30 p.m.

"The application of glass in chemical industries"—K. J. Molineux. Mr. Molineux is a chemical engineer with Q.V.F. Ltd. This talk should be very informative on a subject we tend to take for granted.

Western Section

A talk to the section on the Design of Glass Workshops was given by Mr. R. Garrard on 31st October. He gave an account of features which had been incorporated in the planning of the glass shop in the School of Chemistry, University of Bristol. The talk was followed by discussions on future gas supplies, non return valves and anti-glare spectacles, the remainder of the evening being occupied by an inspection of the extensive collection of new items of equipment.

J. H. BURROW

16th November, 1966

Proposed New Section

Permission has been granted to me as Chairman to investigate the possibility of forming a new Section in the region of East Anglia. There are many members North of London who, owing to geographical location, have difficulty in attending the meetings arranged by the Southern Section which take place in London.

The proposed Section would be known as the East Anglian Section and its boundary would be as follows: from King's Lynn, Norfolk, draw a line to Baldock, Herts., to Harlow and Colchester, Essex, and through to the East coast. Cambridge would be the City selected for all lectures and other meetings which could be held in the University or in the premises of various local companies.

In order to ascertain the possible strength of the new Section, will all members residing in

this area, together with members south or west, who would also find Cambridge more easily accessible than London, please supply the following particulars:—

Name.....

Full Student or Associate Member.....

Address.....

.....
Could you attend Lectures in Cambridge
once a month?.....

Have you any special preference of evening
and time?.....

Constructive observations and volunteers to
help in running this new Section will be
appreciated and replies should be sent to:—

E. G. Evans, 65 Frambury Lane, Newport,
Essex

LETTERS

The Editor

JOURNAL OF THE B.S.S.G.

Dear Sir

With reference to your editorial comment in the September issue of the Journal regarding the compulsory examination for full membership of the Society, I wish to endorse the views that you expressed and venture to suggest that this rule, although passed at the last Annual General Meeting, does not receive general support from the membership.

Our Society is at present in its infancy, and it can be appreciated that mistakes may well be made at this stage, but once an error is realised it should be rectified without delay. If the members wish it, it is not too late to rescind this rule, and a case might well be made to call a Special General Meeting to do so; this might well depend on what reaction your excellent editorial has had from its readers.

Your comment that the original intention of the certification scheme should be a voluntary one is true and, as such, it should receive every encouragement, and it is my wish that the Society should instruct the board of examiners to implement a voluntary examination scheme.

It should be remembered by members that the Board of Examiners is a sub-committee of Council. This sub-committee has been delegated a very important task to perform on our behalf, and it is also important that we should keep a close watch on what this committee is doing in our name.

One of the important, if not the most important functions of the Journal is that it is a common link with every member of our Society, in certain cases due to geographical location or apathy in attending section and general meetings, it is the only link that some members have with their fellow glassblowers, so from the pages of the Journal may I make the plea . . . attend your section meetings and let your views be known in order that democracy can play its part.

JOHN W. PRICE

Extract

Another letter, from Mr. J. Kay of the Physics Department, University of Manchester, states that he has given considerable thought to the September editorial and also mentioned a difficulty which emerged during question-time at the Leeds colloquium. Some members have great difficulty in getting their employers to recognise the need for equipment and to allow time off to attend Society works visits, etc., and the question of expenses is even more difficult.

His view is that the Society could help both these members and itself by circulating copies of the Journal and other Society information to these employers so that they are made aware of the conditions existing in other establishments.

In addition, he is of the opinion that we should pay more attention to the recruitment of student members and, on joining, should supply them with copies of the examination syllabus.

REVIEW

Burners and Flame Technology

R. Cescotti, W.S.A. Engineering Co. Ltd.

MANY members of the Society have at some time enjoyed listening to Mr. Cescotti's lecture on Burners and Flame Technology with its numerous carefully prepared planned demonstrations illustrating types of combustion and the physical factors which control the burning of the fuel gases in general use.

His lecture also includes a description of injector systems he has devised to give correct flames with gases of low combustion velocity such as propane, butane and petrol-air gas, and

also for hydrogen enriched mixtures. The latter subject is likely to be of great importance in the future.

The subject matter of the lecture is presented in a monograph, written with meticulous care, containing many first-class illustrations, and printed and bound to a very high standard. Copies may be purchased from Mr. Cescotti who, incidentally, is a member of the Society.

J. H. BURROW

SUMMARY OF PAPERS READ AT 11th ANNUAL SYMPOSIUM OF THE AMERICAN SCIENTIFIC GLASSBLOWERS SOCIETY BOSTON MASS., 8th, 9th & 10th JUNE, 1966

DESIGN considerations in high temperature vacuum systems used in gas analysis. James V. Derby, Westinghouse Electric Corporation, Madison, Pa.

Mathematics and the glassblower. J. L. A. French, Department of Chemistry, University of Toronto, Toronto, Ontario, Canada.

The Glassblower and the Optical Pumping of Lasers. Charles H. Church, Westinghouse Research Laboratories, Pittsburgh, Pa.

The Glass Laser. C. Hyrayrma & N. T. Melamed, Westinghouse Research Laboratories, Pittsburgh, Pa.

Pressure Sintering. A versatile method of materials preparation. Peter R. Sahm, R.C.A. Laboratories, Princetown, N.J.

Gas Laser Tube System. Edwin E. Eckberg, Ecklux Vacuum Laboratory, Bedford, Mass.

Tin Oxide. What we can do with it. Henry D. Coghill, General Electric Company Research and Development Centre, Schenectady, New York.

Electronically Conducting Glass. Joseph H. Rosolowski, G.E.C. Research and Development Centre, Schenectady, New York.

Sealing Gases at High Pressures into Standard Wall Glass Tubing. John Lees, Department of Physics, University of British Columbia, Vancouver, S. Canada.

Alkali Free Glasses. Robert H. Miller, Consumer and Technical Products Division of Owens Illinois Inc.

Protective Valve for the Glassblower. W. John, Air Force Avionics Laboratory, Wright Patterson Air Force Base, Ohio.

A Glass Laser Coupling Reflector. Charles A. Bennett, Frankford Arsenal, Philadelphia, Pa.

Centrifuging Glass Tubing. E. G. Evans Fisons Pest Control, Saffron Waldon, Essex, U.K.

The Scientific Glassblower in Petroleum Exploration Research. Dr. J. T. Weisman, Gulf Research and Development Company, Pittsburgh, Pa.

World Outlook for Glassblowing Challenges of the Future. Olaf M. Loytty, Corning Glass Works, Corning, New York.

Thermal Energy Coatings for Glass Refractories. Charles M. De Woody, Ace Glass Inc., Vineland, N.J.

Advances in Solder Glass Technology. K. G. Lush and W. E. Smith, Consumer and Technical Products Division, Owens Illinois Inc., Toledo, Ohio.

New Developments in Glass Technology. George W. McLellan, Corning Glass Works, Corning, New York.

A Technique for Evaluating and Controlling the Sealing Properties of Glasses.

H. E. Powell and E. M. Tom, Owens Illinois Inc., Toledo, Ohio.

NOTE: These papers will be published in a complete volume obtainable from the A.S.G.S., a copy of which we hope will be included in the Society Library.

LIBRARY

THE idea of forming a library is to enable the Society to provide an information service to any member. This service may be the loan of a book for normal study purposes or to enable an author to obtain facts about glass in the preparation of a future paper—possibly to be read to or published by the Society—or, of course, to be read for sheer pleasure. It is hoped to rapidly provide reviews of new glass literature, these reviews to be published in the Journal. Also records of our Society must be preserved as must the writings and activities of its membership and in the interest of present and future scientific glassblowers a library is the place for such preservation.

Searching for facts about a subject can be a long and arduous task. On the other hand, access to a comprehensive collection of literature on a particular subject may mean at least a great saving of time. Furthermore, the availability of most of the major works on one's subject enables a greater factual coverage to be obtained.

I would like to appeal to members of the Society to help build our library by donating any books on glass or related subjects which they

feel able to release, particularly some of the older works which are now difficult to obtain. If you can help in this way do not send books, but just let me have the titles, authors, and if possible, the date of publication. I will arrange collection in due course.

Finally, a list of books is being compiled and suggestions from members of any literature which they think should be in our library will be most welcome. Please address all correspondence to :

59 Whitedown Road
Tadley
Basingstoke
Hants

S. D. FUSSEY

WANTED

Heathway drop sealer, pressed base machine.
Lathe, Radyne Heater, Hydrogen stove.

V. N. BARRETT & CO.
18 Sherwood Road
Addiscombe, Croydon
Surrey
Addiscombe 6470

BRITISH



MADE

We are specialists in . . .

HAND-DRAWN GLASS TUBING & ROD

SCIENTIFIC

COLOURED TUBING AND ROD

INDUSTRIAL

RE-DRAWN SMALL CAPILLARIES

THERMOMETER

PRECISION BORES

SEALING GLASSES

MOULD-BLOWN CYLINDERS

IN SODA, LEAD, BOROSILICATE AND SPECIAL COMPOSITIONS

Clear, Clear-Coloured, Opaque

PLOWDEN & THOMPSON LTD

DIAL GLASS WORKS · STOURBRIDGE · WORCESTERSHIRE

Telegrams : DIAL, STOURBRIDGE

Telephone : STOURBRIDGE 3398

Advanced Techniques to Guard your Budget and Speed Production

THE
PORTABLE

'CUTANGRIND'

Machine with
DIAMOND WHEELS



For every form of
Cutting and Grinding
Glass and Silica tubing
(6in. or more)

Geological samples
attachment (for slicing)

Ceramics, Refractories

Concrete, Tungsten

Carbides

Solid State Materials, etc.

Size : 17in. x 17in. x 12in.

Weight : 46 lb. net

Motor : $\frac{1}{4}$ h.p. Capacitor

Fitted with 5in. Diamond saw with adjustable height control, depth of cut $1\frac{1}{2}$ in.
(3in. by revolving) Face and peripheral wheels interchangeable

ALL PARTS RUSTLESS NO SPLASHING MANY VERY SATISFIED CLIENTS
ECONOMICALLY PRICED

Made by experts with 20 years' unrivalled knowledge in the manufacture and uses
of diamond impregnated saws, wheels and drills

FOR PULVERIZING, ANALYTICAL — PRODUCTION

A.G.S. MACHINES all with Agate working surfaces

CONTINUOUS CONE GRINDER MORTAR MACHINE MICROMILL
DIAMOND TOOLS FOR ALL PURPOSES

Write for catalogue to

AGATE & GENERAL STONECUTTERS LTD

25 HATTON GARDEN, LONDON, E.C.1

Telephone : EDGWARE 2558

DIAGRIT

TAPER GRINDING TOOLS

FOR LABORATORY
GLASSWARE & CERAMICS

The simplest, cleanest and most effective way of producing accurate male and female tapers in glass and ceramics at one tenth of the previous operation time. The secret lies in the steel core coated with diamonds in a spiral pattern, giving a reamer life of between 3,000 and 6,000 bores according to the accuracy of the preformed joint.

Diagrit range of diamond taper tools covers all standard sizes and includes tools designed by us to suit special applications. Send for our catalogue showing the comprehensive range of diamond tools. Our Technical Department is available to advise you

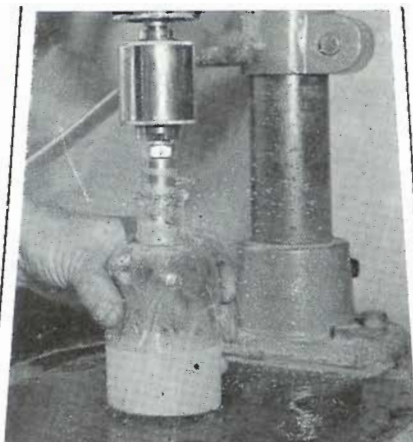

Taper reaming a 500 cc bottle to size B24. A badly chocked bottle will be completed in 5-10 seconds



Taper reaming a borosilicate glass desiccator lid, size B34, at the works of Jencons (Scientific) Ltd., Hemel Hempstead. This operation is completed in only a few seconds. Tools can be supplied to both drill and ream out the hole in one operation

DIAGRIT ELECTROMETALLICS LTD.
STAPLEHURST, KENT.
Phone STAPLEHURST 662

THE "SILENT" HIGH POWER OXY-PROPANE BURNER

DEVELOPED BY US FOR WORKING
FUSED SILICA TUBING

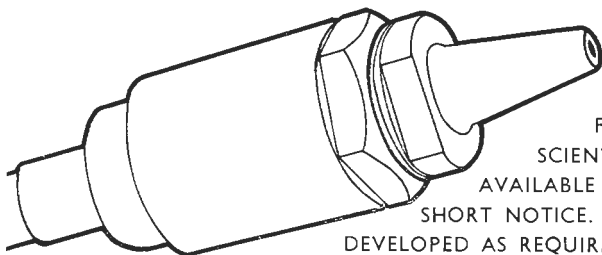

ALL REQUIREMENTS
FOR INDUSTRIAL AND
SCIENTIFIC GLASSBLOWING
AVAILABLE FROM STOCK, OR AT
SHORT NOTICE. SPECIAL EQUIPMENT
DEVELOPED AS REQUIRED

QUADRANT ENGINEERING CO LTD

PERREN STREET, LONDON, N.W.5

Telephone : GUL 5516

**HIGH
PURITY
TRANSPARENT
QUARTZ-GLASS**

For the last 16 years we have supplied all the largest laboratories in this country with our quartz-glass and, due to our prompt delivery, have enabled them to continue their important work uninterrupted.

We make most complicated apparatus for atomic research, Universities and other laboratories.

If you have any problems concerning quartz-glass let us solve them for you.

KAREL HACKL

211 Sumatra Road, London, N.W.6

Telephone : SW1 5656

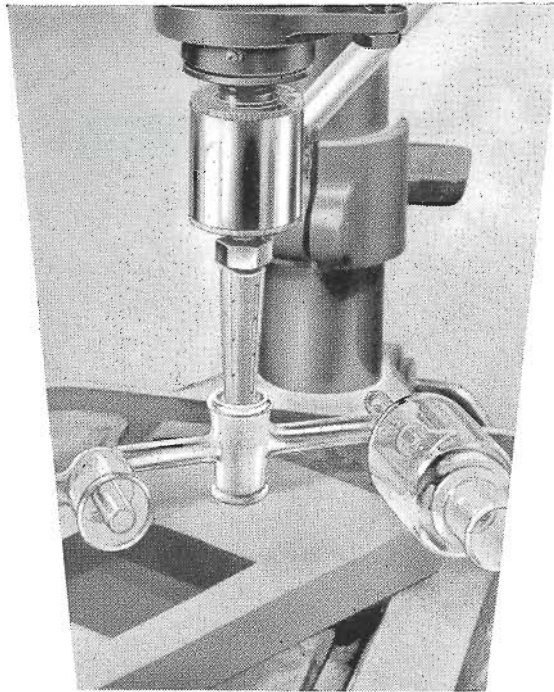

HABIT

CONE & TAPER DIAMOND IMPREGNATED REAMERS FOR GLASS

Grind accurate Taper sockets
and plugs to B.S.S.
or other specifications at
Very High Production Rates

If you are not completely
satisfied with your present
methods—call in HABIT
—Engineers with Experience

HABIT DIAMOND TOOLING LTD
LURGAN AVENUE . LONDON W6 . Telephone : FULham 7944

Cone No. 12

Heathway Glassworking Lathes

We have 25 years' design experience on lathes and our machines are quality engineered at competitive prices

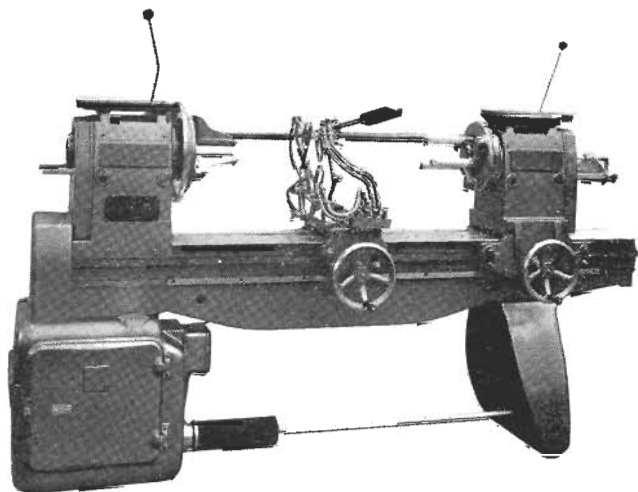

Heathway latest designed Glassworking Lathe (as shown above) with the following new specification—

- ★ New wide bed section
- ★ Foot drum speed control
- ★ Spindle speeds infinitely variable 20-475 rpm
- ★ 6 splined main drive shaft, completely covered by bellows
- ★ Electric clutch to disengage tailstock

HEATHWAY MACHINERY CO. LTD

UXBRIDGE ROAD HILLINGDON, MIDDLESEX Telephone UXB 36345