

# JOURNAL

OF THE

## BRITISH SOCIETY OF SCIENTIFIC GLASSBLOWERS

Vol. 6

DECEMBER 1968

No. 4

## EXE GLASS LATHES

are not only precision built but have proved they maintain their accuracy after many years of constant use. They have many special features including an unusually wide speed range which covers tube coiling to centrifugal action

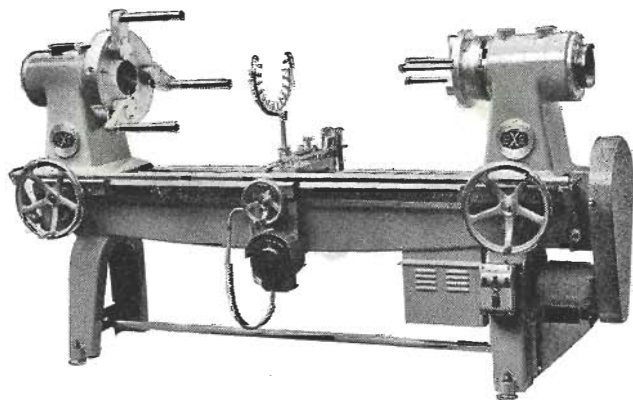

Many years' experience of development and production of Glassworking Lathes enable us to offer a wide range of LARGE, MEDIUM and SMALL LATHES suitable for research and production purposes.

When enquiring please state your requirements, including distances between spindles, swing and spindle bore also the general purpose.

THE **EXE** ENGINEERING CO. LTD  
EXETER ENGLAND  
Telephone Exeter 75186-7

### CONTENTS

	Page
Editorial . . . . .	57
Council Meeting . . . . .	58
Glass Diffusion Pumps D. F. Klemperer Ph.D. . . . .	60
Section Activities . . . . .	76

#### Editor

J. H. BURROW  
H. H. Wills Physics  
Laboratory  
Royal Fort, Clifton, Bristol

#### Advertising & Finance

C. H. GLOVER  
"Saraphil" Highfield Lane,  
Cox Green, Maidenhead,  
Berks.

#### Abstracts & Library

S. D. FUSSEY  
A.W.R.E., U.K.A.E.A.,  
Aldermaston, Berks.

#### Distribution

I. C. P. SMITH  
16 Hunts Mead,  
Sherborne, Dorset.

9th October 1968

British Society of Scientific Glassblowers

Dear Members,

I came away from the Symposium at Lytham St. Annes, and I thought once again I have had a wonderful time, and as with previous symposiums I have meant to write to all the people who have worked so hard and thank them, but I must confess I never have, so I have chosen this way to write to you all, to thank you all most sincerely.

Lastly I must mention how impressed I am with the progress that the Society has made over the last few years, it is now a Society to be proud of.

I am,

Yours sincerely,

A handwritten signature in black ink, appearing to read 'A D Wood'. The letters are cursive and somewhat stylized, with the 'A' and 'D' being particularly prominent.

A. D. WOOD

# A technical breakthrough in glass ›

## *Clearfit*<sup>®</sup> joints by Quickfit<sup>®</sup>

- Lubrication will not be necessary for many preparations.
- Less danger of joints seizing.
- Simple to clean, even with radio chemicals.
- Improved vacuum seal, without lubrication.
- Interchangeable with Quickfit ground joint range.



® REGISTERED TRADE MARKS

Write for Clearfit catalogue and  
Clearfit joints leaflet

QUICKFIT & QUARTZ LTD  
STONE STAFFORDSHIRE

Telephone STONE 2121 Telex 36226

QUARTZ SOCKETS

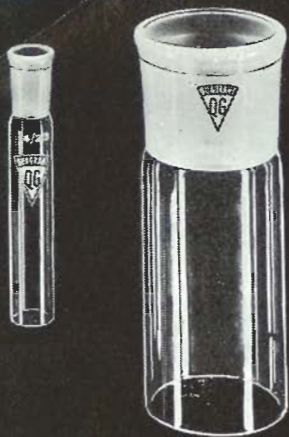

QUARTZ CONES



QUARTZ BALL JOINTS

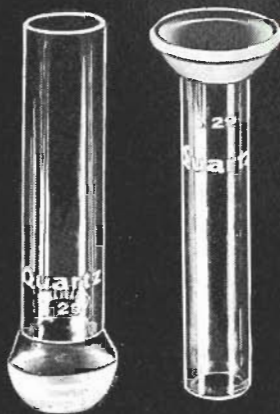

GRADED SEALS

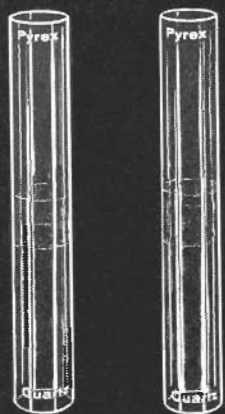

QUARTZ FLANGES

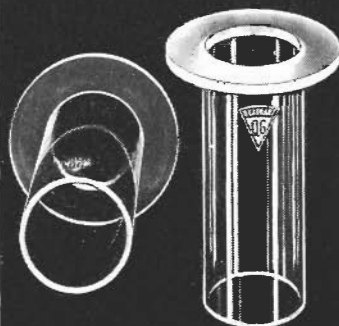

GLASS TO METAL SEALS

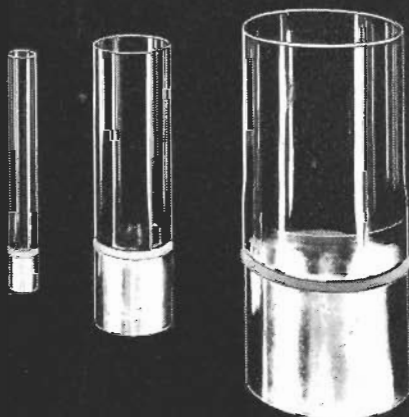

# Quadrant 'Standards' in regular demand



Variations to these "Standards" are readily available - let us quote for your special needs.

**QUADRANT GLASS CO. LTD.**

The Pinnacles, Harlow, Essex  
Tel: Harlow 21315

# HEATHWAY

## BELL TYPE ANNEALING OVEN



OVEN 'UP POSITION'

Operational advantages of this design are:  
Versatility—easy loading—flexibility of operation—heat lost when opening minimized.

*Specification:*

Normal 'Up and Off' and 'Up and Hold' plus temperature setting. Maximum operating temperature 650°C.

Inside dimensions of Bell:

60" long 21" high 17½" wide.

*May we send you details of our range of lathes and equipment?*

**Write or Phone**

**The HEATHWAY MACHINERY CO LTD**

UXBRIDGE ROAD, HILLINGDON, MIDDLESEX

Tel. UXB 36345/6 Grams. HECO UXBRIDGE



OVEN 'DOWN POSITION'

Or contact one of our Overseas Agents: Canada: Nortel Manufacturing Ltd.—Scarborough, Ontario. France: P. Foulon—Paris. Holland & Belgium: A. Bruyaux—Amsterdam. Australia: H.B. Selby. Scandinavia: Kebo—Stockholm. U.S.A.: Bethlehem Apparatus—Hellertown PA. Switzerland: Ernst Keller—Basle. Germany: &Hann Kolb—Stuttgart.

# STOPCOCKS complete range by SPRINGHAM

## HIGH VACUUM Hollow Key

Pyrex Glass, precision ground. Each INDIVIDUALLY TESTED and GUARANTEED. Early delivery

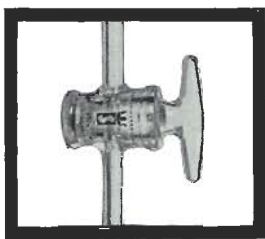

## P.T.F.E. (FLUON) Greaseless

For use with liquids requiring no Grease. Essential for Acids, Alkalies, Caustic Soda, Solvents, Hydrocarbons and Gas Chromatography. Fully interchangeable with INTERKEY range of Stopcocks and Apparatus

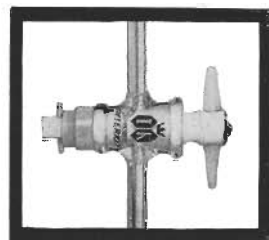

## NEW SOLVAC High Vacuum Solid Key

Save 25% on cost Individually tested and Guaranteed  $10^{-6}$  mm Hg. Early delivery

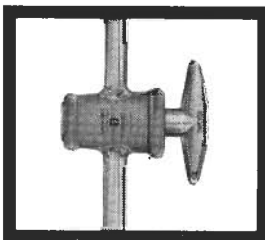

## MICRO CONTROL p.t.f.e. (Fluon)

For use with liquids at less than 1 drop per second. No grease and also fully interchangeable with INTERKEY range of Stopcocks and Apparatus

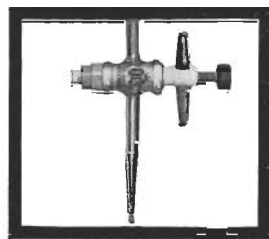

## HIGH VACUUM Greaseless

Using VITON "A" or NEOPRENE diaphragm with Pyrex glass body, giving fine control and performance of  $10^{-6}$  or better at  $-60^{\circ}$  to  $450^{\circ}$ F.

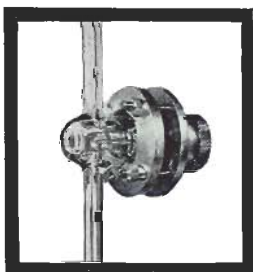

Sizes 1mm to 10 mm bore — all parts interchangeable.

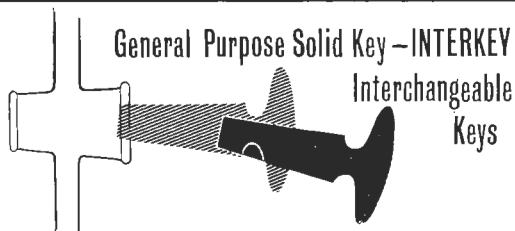

All sizes 1 mm to 8 mm bore. Straight pattern, Single oblique, Double oblique, "T" and "Y" bores

- \* No Leakage
- \* Early Delivery
- \* Spare Keys
- \* Immediate Key replacement



Descriptive literature and price lists available from

**G. SPRINGHAM & CO LTD** HARLOW NEW TOWN, ESSEX - HARLOW 24108

**NEW**  
SEPARATING  
FUNNEL  
STOPCOCKS



**INTERKEY<sup>R</sup> STOPCOCKS**

(EX STOCK DELIVERY)

Interchangeable keys, GLASS or P.T.F.E. available

Cat. No. Key No. Bore mm.	STO/2/F1 2/2 2	STO/4/F2 4/4 4	STO/6/F3 6/6 6
COMPLETE	12/9 Ea. 11/9 Ea./doz.	16/6 Ea. 15/- Ea./doz.	25/6 Ea. 23/6 Ea./doz.
Barrels only	10/- Ea. 9/3 Ea./doz.	13/3 Ea. 12/- Ea./doz.	18/- Ea. 16/6 Ea./doz.
Glass Keys only	2/9 Ea. 2/6 Ea./doz.	3/3 Ea. 3/- Ea./doz.	7/6 Ea. 7/- Ea./doz.
P.T.F.E. Keys only	37/9 Ea. 32/3 Ea./doz.	48/6 Ea. 43/- Ea./doz.	— —

Repair your  
broken funnels  
**QUICKER  
CHEAPER &  
BETTER**

Available with cone on stems as follows :-  
B.14 11/- ea. B.19 13/- ea. B.24 15/- ea. extra

**SPRINGHAM QUALITY with robust wall tubing  
HEAVY WELDS, GUARANTEED PERFORMANCE**

**G. SPRINGHAM & COMPANY LIMITED, BAY 35, SOUTH RD.,  
TEMPLEFIELDS, HARLOW, ESSEX Tel. 24108 & 21170**

BRITISH



MADE

*We are specialists in . . .*

**HAND-DRAWN GLASS TUBING & ROD**

SCIENTIFIC

COLOURED TUBING AND ROD

INDUSTRIAL

RE-DRAWN SMALL CAPILLARIES

THERMOMETER

PRECISION BORES

SEALING GLASSES

MOULD-BLOWN CYLINDERS

IN SODA, LEAD, BOROSILICATE AND SPECIAL COMPOSITIONS

*Clear, Clear-Coloured, Opaque*

**PLOWDEN & THOMPSON LTD**

DIAL GLASS WORKS · STOURBRIDGE · WORCESTERSHIRE

Telegrams : DIAL, STOURBRIDGE

Telephone : STOURBRIDGE 3398



# British Society of Scientific Glassblowers

Founded 1960

*Chairman*

E. G. EVANS  
65 Franbury Lane  
Newport, Essex

*Secretary*

J. W. STOCKTON  
34 Kildonan Rd., Grappenhall,  
Warrington, Lancs.  
Tel. 63162 Home  
31211 Ext. 28 Business

*Treasurer*

L. BERGE  
75 Birchen Grove,  
London, N.W.9

## EDITORIAL

We have set out the more interesting points of the 30th November Council meeting on Page 58 but the hope that the procedure outlined on page 37 of the September issue would result in a more streamlined meeting was not fulfilled and there have been repercussions in the form of circular letters. But we should keep a sense of proportion; though it may seem a little strange that the Society which in many respects is flourishing, with a reasonable membership, sound financial state, first-class Symposia and plenty of external interest and goodwill, still has difficulty in achieving a smooth administration and as a consequence many feel the progress of the Society is being delayed.

But this may not be so surprising when we remember that in our profession we have a reputation for individualism added to which Council members are widely separated geographically and as a result have wide differences in thought and expression even though the common aim may be a sound progressive Society. In Council we try to run on democratic lines and any move which may infringe on this principle is challenged, but the net result is difficulty in reaching agreement. We should also examine the method whereby Councillors and Section Representatives are elected, for if the system does not come up to expectations, it is the individual responsibility of each voting member and he should do his best towards choosing those who will attend Council in a constructive spirit and if possible take an active part in the management of the Society. It must be remembered that those who voluntarily carry out the practical side of Society administration come to the Council by way of election by members at Section level. They have a right to expect encouragement and help and mere verbal wisdom is not enough.

Perhaps this democratic system is not the best that can be devised and a smaller elected Council with power to co-opt for defined executive purposes might work better, or alternatively the responsibility to provide the main officers of the Society could be given to the Sections in rotation, the case for the latter being that this has worked well in the case of Symposia.

But few will want to make a drastic change and indeed there is no need providing each member of the Society is kept accurately informed as to what happens at Council level.

---

### Obituaries

We regret to record the death of Mr. Stan Elliott, son of H. J. Elliott who joined the well-known firm of H. J. Elliott Ltd., E-Mill Works, Treforest, Glam. in 1927.

This glassblowing business one of the oldest in the country was founded by H. J. Elliott in 1911.

A memorial service will be held at Llandaff Cathedral, Cardiff at 12 noon on the 15th January 1969.

We must also record the tragic death of Mr. David Geoffrey Flack aged 18, a Student member who died on January 2nd after a motor cycle accident while travelling to work at Leeds University.

---

The Journal is published quarterly by the B.S.S.G. and is available free to members and at 10s 0d per copy (or 35s 0d per annum) to non-members. A limited number of back copies are available. Editorial communications should be addressed to the Editor, c/o H. H. Wills Physics Laboratory, Royal Fort, Clifton, Bristol 8, and enquiries for advertising space to C. H. Glover 'Saraphil', Highfield Lane, Cox Green, Maidenhead, Berks. Printed in Gt. Britain by Sawtells of Sherborne Ltd., Sherborne, Dorset. Copyright B.S.S.G. and Contributors 1967.

## COUNCIL MEETING 30th NOVEMBER 1968

The agenda for this meeting had been drawn up and circulated by our new Secretary Mr. J. W. Stockton, in an endeavour to follow the procedure for Council meetings which appeared on p. 37 of the September Journal. However, there were strong objections on principle by some members with respect to any restriction of items for the agenda or limiting discussion on any particular subject and though it was pointed out that this is a common procedure in the case of company board meetings, it was felt that we should not do this. Although no formal motion appears in the minutes the Journal is asked to correct the p. 37 statement.

### Treasurer's Report

Mr. L. Bengé presented an up-to-date survey of the Society's finances which, allowing for estimated expenditure, indicates that the balance of income over expenditure for 1968 will be very satisfactory.

A breakdown of 1967 expenditure and income in terms of average per member was also given as follows:—

<i>Income</i>	From subscriptions	£1 18 5	
	Dinners etc. ...	6 10	
		£2 5 3	
<i>Expenses:</i>			
	Administration ...	18 4	
	Journal ...	5 5	
	Sections ...	9 6	
	Reserve ...	12 0	
		£2 5 5	

The final balance sheet for 1967 was also circulated.

Mr. Bengé was thanked for his clear statement of the Society's financial position and he hopes to present 1968 balance sheet in the same way.

### Travelling expenses

On the question of travelling expenses of Section Representatives and Councillors attending meetings in Birmingham, opinions were expressed that the present arrangement of claiming half rail fare was not realistic and was liable to deter members from attending. It was felt that where it was necessary to incur greater expense that payment should be made.

It was agreed that winners of trophies presented at the Annual Symposium should be eligible for travelling expenses to enable them to attend in person — each case to be negotiated with the Treasurer.

### Journal

Mr. C. Glover gave a complete survey of Journal finance dating back to its beginning and copies were circulated to all Council members. He too was thanked for his clear and comprehensive statement.

The Editor in his report gave reasons why the Journal is nearly always late in distribution and as a consequence the receipt of advertising dues is further delayed. This creates a gap between income and expenditure and he is unable to submit for printing until Council guarantees any deficiency at the time when printing accounts are rendered. The December Journal was now held up for this reason.

Advertising rates are to be further increased in 1969 in an effort to make the Journal show a profit.

With regard to publication of Annual Symposium papers it was felt that though ideally these should be published as a separate volume we are not yet financially strong enough to do this and the Editor was then given instructions to proceed with the publication of Dr. D. Klemperer's paper on Glass Diffusion Pumps to be included in the December issue.

### 1968 Symposium

Figures were given showing an income of £317.5.0 and a possible surplus of about £61 when settlement is complete.

A proposal was made that profits should be put into a reserve for future Symposiums but was not carried and the previous practice of transferring to the general fund is to be continued. All members of the Society will wish to thank the North Western Section for their work in arranging this highly successful event.

### Rule Books

It was agreed that a new edition should now be printed and authority was given to the Secretary to proceed.

### 1969 Symposium

A preliminary announcement was made that this Symposium will be organised by the *East Anglian Section* and will take place on the 19th and 20th September at the *Royal Hotel, Clacton-on-Sea, Essex*.

The overall title will be "*Applied Techniques of Scientific Glassblowing*" and the full programme will be published later.

The following Officers have volunteered their services:—

<i>Secretary</i>	— R. Adnitt, 26 Home Close, Harlow, Essex.
<i>Treasurer</i>	— D. W. Smith, 57 Rylstone Way, Saffron Walden, Essex.
<i>Registrations</i>	— A. Willis, 269 Little Brays, Harlow, Essex.
<i>Trade Stands</i>	— R. Radley, 53 London Road, Sawbridgeworth, Herts.
<i>Accommodation</i>	H. Morrison, 27 Newfields, Welwyn Garden City, Herts.

### Dates of Future Council Meetings

15th February, 17th May, 19th August and 15th November 1969.

## LETTER TO EDITOR

Dear Sir,

### Procedure at Council Meetings

I was very glad to see the notes under this heading on the Editorial page of the September issue, and hope that the Officers may be able to implement their proposals. These are very much in line with those of other Society Councils, and I can see no point to which any member or Section could take exception. Under (4) Time Limits, it could additionally be desirable (a) to limit the time allowed to any one speaker, and (b) to allow any member to speak only once. Under (5) Emergency Decisions, there can be no cause for uneasiness, as (a) a decision would only be taken on matters of routine, which could not wait till the next Council meeting, (b) such decisions will be reported at the next Council meeting, when members would be free to criticise, if criticism were called for, and in particular (c) the officers have been elected to that position because they had the trust of the members, and the best interests of the Society at heart.

Yours sincerely,

(signed) I. C. P. SMITH, B.Sc.

## TECHNICAL NOTE

### SAWING GLASS *See page xi*

The hint mentioned in the Southern Section report highlights the fact that faster cutting and longer life of diamond impregnated tools can be obtained by a careful study of the supply of fluid to the cutting edge, and the present arrangement of jets on many commercial cutting machines does not always give the best results. In the writer's case the efficiency of diamond impregnated and carborundum saws has been considerably increased by directing the fluid into a central hole in the machine spindle from which via ducts in the mounting flanges it is centrifuged over the wheel surface and into the cut. A much greater proportion of the fluid used is effective. Good results are also obtained by the creation of a mist by directing the jets into the saw guard when it will again be found that the cutting edge is well supplied.

Many other points such as position of work, speed and direction of rotation of saw are involved and the assembling of information on abrasive glass working could result in an article of great value to both those who manufacture and use equipment sold for this purpose.

J.H.B.

## ABSTRACTS

Compiled by S. D. Fussey A.W.R.E.

### EDUCATION

(541) **Light Units in SI.**  
F. A. Sowan, *Mullard Tech. Comm.*, 10, 95, pp 182-184, Sept. 1968. The author's aim is to disentangle the confusion that tends to surround the main photometric units. The four photometric quantities are defined and evaluated, and the preferred metric system units stated. Bibliography for further study. S.D.F.

### GLASS

(542) **The Properties of Borosilicate Glass.**  
P. Heslop, *Lab. Pract.*, 17, 9, 1024, Sept. 1968. Paper setting out the more significant properties of borosilicate glass manufactured by James A. Jobling. B.R.W.

### GLASS APPARATUS

(543) **Simple Glass-Teflon Circulating Pump for Gases and Liquids.**

E. Hyland & M. J. Joncich, *Fusion*, 3, pp 9-11, Aug. 1968. A simple, cheap pump capable of circulating gases and liquids for long periods. A teflon-encased iron nail within a glass tube serves as a piston and is made to oscillate by a solenoid and gravity. Detailed sketch and refs. S.D.F.

(544) **A Simple Dewar for Spectroscopic Measurements at Controlled Temperatures down to 77°K.**

J. P. Simons, *Jour. Sci. Instru.*, 1, series 2, 872, Aug. 1968. Dewar permitting recording of ultra-violet and visible spectra in absorption and transmission in temperature range 77-450°K. The refrigerant does not impede light path and window does not cloud over. Constant temperature can be maintained and cell contents reach refrigerant temperature in a few minutes. Details of construction with drawing and photograph. D.A.H.

(546) **Chambers for Thin Layer Chromatography Using Glass Rods.**

J. T. Streater, *Jour. Chem. Educ.*, 45, 10, 67, Oct. 1968. Conical flask, with rod fused to stopper, enabling vertical draining to occur. F.G.P.

(547) **Determination of Mol-Wt. of Air Sensitive Compounds.**  
F. Walker & E. Ashby, *Jour. Chem. Educ.*, 45, 10, 655, Oct. 1968.

A 3-piece equipment based on Cottrell B.P. apparatus. Dry and oxygen-free conditions are able to exist. F.G.P.

Further Abstracts held over

Ed.

### LIBRARY INFORMATION

The Society Library wishes to acknowledge a further donation from Quickfit & Quartz. On this occasion they have presented us with an autographed copy of R. Barbour's new book *Glassblowing for Laboratory Technicians*. A review of this book will appear in a later edition of this journal.

Two further publications have been received from the Industrial Diamond Information Bureau. (L 13) *Diamond Abrasive Wheel Technology* by V. Conradi and (L 16) *Interrupted Cutting of Tungsten Carbide with Diamond Abrasive Grinding Wheels* by F. Hughes and E. A. Dean.

S.D.F.

### CLASSIFIED ADVT.

#### Precision Bore Tubing

0.95 mm. I.D. 6-7 mm. O.D.  
For disposal - 576 ft. in 20" lengths.  
Offers invited. Mr. Ledger, Hemel Hempstead

Tel. 56371

# Choose JOINTS in VITREOSIL®

for chemical apparatus  
where high operating temperatures  
and purity matter!

The extensive precision grinding facilities available at our Wallsend works enable us to offer a large range of standard specification joints for easy assembly of apparatus. Buttress joints especially enable vitreous silica and borosilicate glass components to be inter-connected. Vitreosil pure fused silica is not affected by acids (with the exception of Hydrofluoric), and can be used continually up to 1000°C.

#### STANDARD TAPER JOINTS

Fully interchangeable to B.S. 572.  
Standard one in ten taper from 5 mm  
to 60 mm diameter (large end).

#### SPHERICAL GROUND JOINTS

Comprehensive standard range  
of sizes to B.S. 2761.

#### BUTTRESS JOINTS

Range of interchangeable joints  
including the larger diameters  
to B.S. 2598.

#### GRADED JOINTS

Vitreosil to Borosilicate and other  
glasses can be supplied in range  
4 mm to 35 mm or to specification.

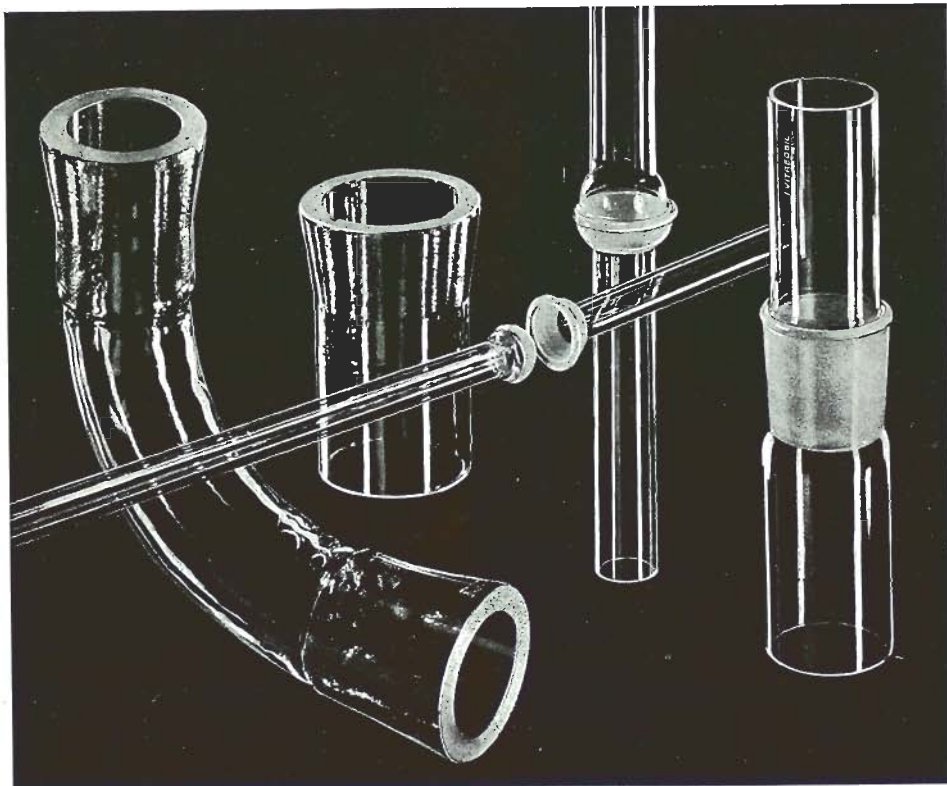

#### THERMAL SYNDICATE LIMITED

P.O. Box No. 6, WALLSEND, NORTHUMBERLAND. Telephone: Wallsend 625311 Telex: 53614.  
9, BERKELEY STREET, LONDON W.1. Tel: 493-1711. Telex: 263945

SILICA INDUSTRIAL WARE • LABORATORY WARE • OPTICAL COMPONENTS • HIGH TEMPERATURE OXIDE CERAMICS

# GLASS DIFFUSION PUMPS\*

by

DEREK F. KLEMPERER, *University of Bristol*

## PUMP ANATOMY AND PURPOSE

It is appropriate to commence any discussion of glass diffusion pumps by describing briefly the purpose and anatomy of a simple pump which bears all the main features essential to this method of pumping gases.

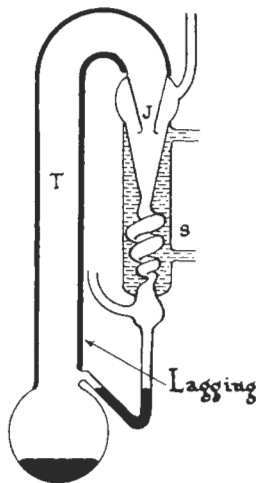

Fig. 1 Volmer mercury diffusion pump

Fig. 1 shows a form of pump due to Volmer (Volmer 1920) which was developed in the nineteen twenties and is still to be seen about the laboratory today. It is of all glass construction, and it contains the work fluid, in this case mercury, shown as black in the boiler and the return limb. The boiler is euphemistically called the kettle in America. Mercury was used exclusively until about 1928 but since that time various oils have also been widely used.

The purpose of the pump is to exhaust gases from a high vacuum system which is connected at the inlet (top right of Fig. 1) and to discharge them through the lower open tube into a region which is maintained at, say,  $10^{-2}$  torr by means of a backing pump. Actually the exact forevacuum pressure needed varies considerably for different types of diffusion pumps, depending on their design, the gases being pumped and also the operating conditions.

Work fluid is volatilized in the boiler under a pressure of several torr. This pressure is determined by the difference in level in the two sides of the return tube during operation. The vapour passes up a lagged heat pipe T, is squirted through

the nozzle J and emerges into the vacuum as a jet of vapour. This jet is expanding freely in a region of low pressure and, as a result, it reaches supersonic velocities soon after emerging. We shall have more to say about nozzles and jets presently but it is important to realise that there would be little pumping action unless the work fluid molecules move with high velocity in the given direction.

When the jet reaches the cooled walls of the water condenser S it is condensed back to liquid and returns to the boiler while the gas molecules extracted from the inlet side are passed out to the forevacuum.

There is no theoretical limit to the base pressure attainable in the high vacuum system. In practice the pressure bottoms out at a level determined by the rate of gas evolution in the high vacuum system and the extent to which the work fluid and pumped gases are prevented from permeating back into the system. Work fluid vapours are usually kept right out of the high vacuum system by interposing a condensation or chemical trap between the system and the inlet. A liquid nitrogen trap is ideal.

The Volmer pump is quite a small one, pumping with a speed of 1 or 2 l/s at the inlet pressure. The precise performance which is measured depends very much on the experimental arrangement used in assessment, so we shall comment on this below.

## COMPARISON TO ALTERNATIVE PUMPS

The pump, thus, needs a cold water supply, power for the boiler and liquid nitrogen for the trap. Bearing in mind that power is also needed for the backing pump, failure in any of these supplies is usually serious. The work fluid is a potential source of contamination and the pump cannot be degassed easily by baking. It must be kept upright and, of course, it shatters all too easily. We might well wonder how this type of pump stands in these days of sorption and cryopumping, gettering, and particularly sputter-ion pumps.

The sputter-ion pump only needs power, and power failure is of no consequence; it contains no mercury or oil, may be attached in any position and is of rugged, bakeable construction. The answer to our question, nevertheless, is that the diffusion pump stands up very well indeed.

The big thing about a diffusion pump is that it goes on pumping – its capacity is limitless. The alternative pumps tend to run on batch processes and they are soon spent if we wish to handle gases or there happens to be a leak. Diffusion pumps are not fussy about what they pump – they

handle large argon loads and are particularly fast for light gases. And the pumped gases are taken right out of the system – there is no question of memory effect. The pumping speed does not fall off at low pressures and there are no powerful magnets or electric fields about.

We use glass diffusion pumps to obtain ultra-high vacuum routinely and conveniently in Bristol and you find them widely used in the laboratory today. Industry also favours the diffusion pump, although size requirements usually dictate a metal construction.

An untrapped oil diffusion pump is chosen on grounds of convenience if oil in the system can be tolerated and very low pressures have been obtained using polyphenyl ether in an untrapped pump. For the cleanest vacua, however, we use mercury in conjunction with a cold trap. It does not creep and cannot give rise to permanent gases.

and integration then yields  $S = \frac{V}{t_2 - t_1} \ln \frac{p_1}{p_2}$  where  $p_1$  is measured at  $t_1$  and  $p_2$  is measured at  $t_2$  in a closed volume  $V$  attached at the pump inlet. Application of this method involves a varying inlet pressure and since speed is not independent of inlet pressure it is usual to employ the so-called constant pressure method.

Constant pressure  $p$  is maintained above the pump by leaking gas into the pump at a measured rate  $V$  in l/s from a source at atmospheric pressure. The speed is then given by

$$S = \frac{\text{Atmos. pressure}}{p} \cdot V \text{ l/s}$$

Unfortunately the results which are obtained vary considerably with apparatus geometry and until recently it was impossible to establish true speeds simply by consulting the manufacturers'

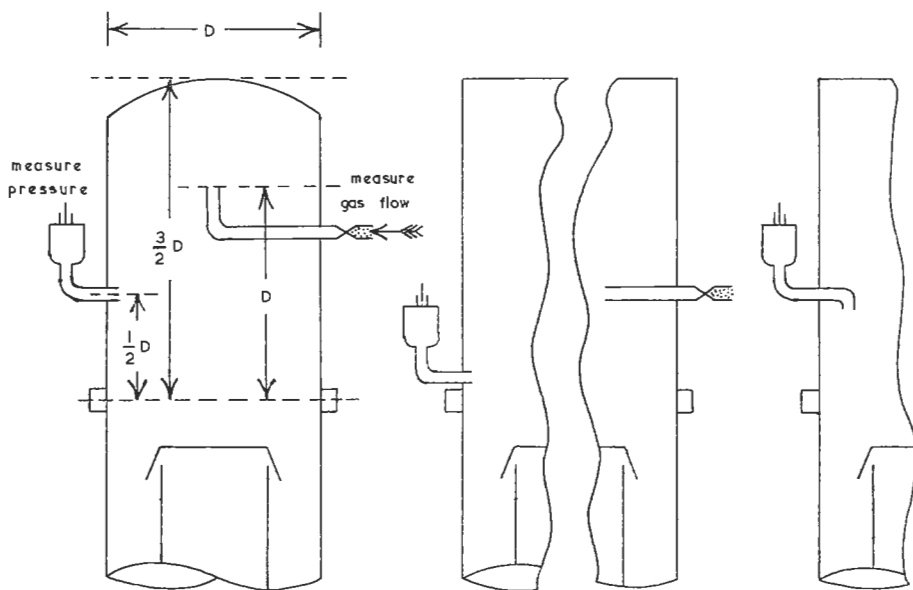

Fig. 2 Test dome for pump speed measurement, as recommended in I.S.O. TC/112

### PERFORMANCE ASSESSMENT

The speed of a pump working under a given set of conditions is defined as  $S = -\frac{dV}{dt}$  in litres of gas at the intake pressure per unit time. It is the most important single characteristic of a pump and we indicate how it can be measured.

The expression for  $S$  may be transformed by application of Boyle's Law to give  $S = -\frac{V}{p} \frac{dp}{dt}$

specifications. The basic problem is that gas streaming effects must be eliminated – the pump should ideally be presented with an infinitely large volume at the inlet pressure, so that gas molecules enter the pump mouth by an entirely random diffusion process.

It is obviously impractical to use very large volumes, but test domes can be made which approximate this situation and present the pump with a so-called cosine distribution of flux.

The test dome recommended by the International Standards Organisation is shown on the left-hand side of Fig. 2 and it is now used by pump manufacturers in this country to measure pumping speeds. The pressure gauge for inlet pressure determination and the tube through which gas is leaked in are not attached in arbitrary positions. Four dimensions are specified, and they depend on the diameter  $D$  of the pump mouth.

On the right of Fig. 2 we see three possible variations by means of which optimistic results can be obtained. The incorrectly placed pressure gauge, the incorrect gas inlet and the incorrect pressure gauge opening all lead to gas beaming effects which cause the pressure readings to be too low.

Unfortunately the I.S.O. test dome is neither perfect, nor is it universally adopted. The current recommendation (T.S.4.1.) of the American Vacuum Society, for instance, permits the pressure gauge to be attached at the top flange of the pump and specifies a slope on the dome head from left to right. On the other hand, it does provide for a constant known dome temperature.

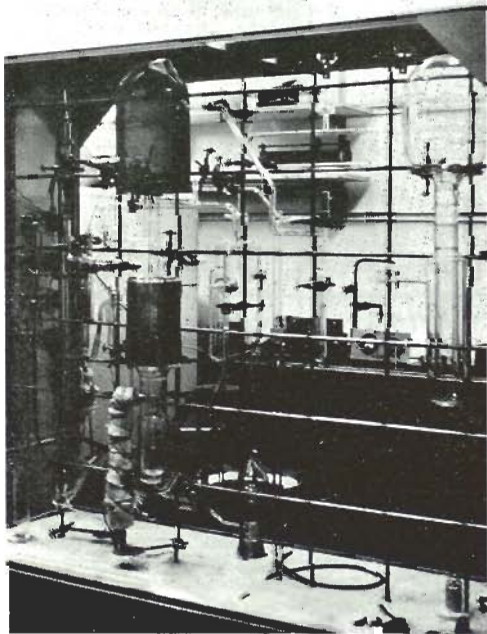

Fig. 3 Apparatus for measuring the speed of diffusion pumps  
(Courtesy of J. C. Snaith)

The apparatus shown in Fig. 3 is used in Bristol to determine speeds and optimum working conditions for a given pump. The constant pressure method is employed, and two test domes which

conform to the I.S.O. standard are prominent in the picture, which also shows the pump under test. Speed is assessed beyond the trap. Of the gas metering devices, that due to Alexander (Alexander 1944) is particularly convenient. In this device a change of pressure near barometric level is measured in the gas reservoir.

## COMMERCIALY AVAILABLE PUMPS

Perhaps the best way of indicating the extent to which glass diffusion pumps are used is to see what is commercially available.

Two dozen glass diffusion pumps which are current catalogue items have been collected in Table 1. Some of these pumps will be described subsequently. Eight are made in this country. We have taken eight from the Continent, chiefly Germany, where diffusion pumps originated with Gaede's experiments and we have also taken eight from the U.S., in honour of Langmuir, who made the first pump as we know it over 50 years ago. The list is by no means exhaustive. Martin, the last entry, in fact illustrates 21 different glass pumps in their current catalogue and there are a number of other pump manufacturers.

In addition to the standard pumps, such as those listed, we must remember that there are firms, such as Glass Appliances Limited, Jencons (Scientific) Limited, G. Springham and Company Limited and T. W. Wingent and Company Limited, who make pumps to customers' specifications. And we have not mentioned all those Industrial and University Glass Shops which currently blow the more difficult pumps for their establishment's needs.

The Working Fluid Column shows mercury or oil except in the case of the Leybold glass steam ejector, which is included for variety and will be mentioned later. We define an ejector as a medium pressure range pump which tolerates high backing pressures and whose pumping speed goes through a maximum as the inlet pressure falls. This maximum is typically at  $10^{-1}$  torr.

The Stages Column refers to the number of jets which are placed in series, each jet backing the preceding one. Jets can also be put in parallel as in the case of the first Martin pump shown. Parallel jet pumps were introduced by Ho in 1932 (Ho 1932). Two or more jets in series results in increased pump speed and increased tolerance to high backing pressures. Parallel jets only increase the speed.

In fact, it is quite common to back the first stage of pumping with a built-in ejector. This is revealed in the Backing Pressure Column — mercury vapour pumps can be made which are suitable for backing with a water jet pump. This cannot, however, be done with oil. As a general rule, high backing pressure is the result of a narrow annular space between the nozzle and the pump wall. This arrangement gives slow speeds, so the preceding stages may have a wide annular

Table 1 Some glass diffusion pumps in 1968 catalogues

MANUFACTURER	CATALOGUE MODEL	WORKING FLUID	STAGES	BACKING PRESSURE REQUIRED	UNTRAPPED SPEED	DESCRIPTION
<b>U.K.</b>						
Edwards High Vacuum Ltd.	EMG	Hg	2	1 torr	9 l/s	Umbrella and Nozzle; ca.10 <sup>-13</sup> claimed with 2 traps
Fisons Scientific Apparatus Ltd.	PMD/3/2	Hg	3	—	3	3 Umbrellas
Jencons (Scientific) Ltd.	Type 1	Hg	2	0.2	30	2 Umbrellas
	Type 2	Hg	2	0.8	17	2 Umbrellas
	Type 3	Hg	2	1	4	2 Umbrellas
Thermal Syndicate Ltd.	S1080	Hg	1	2	—	Nozzle
	S1060	Hg	2	10 <sup>-2</sup>	—	2 Umbrellas
	S1070	Hg	3	10 <sup>-2</sup>	—	3 Umbrellas
<b>CONTINENT</b>						
Balzars Aktiengesellschaft	DIFF 20G	Oil	2	6.10 <sup>-2</sup>	4	Hickman, fractionating
Jenaer Glaswerk	3Q6	Hg	3	15	6	2 Umbrellas and Nozzle
	3B4	Oil	3	3	4	2 Umbrellas and Nozzle
	3O100	Oil	3	10 <sup>-1</sup>	100	3 Umbrellas, fractionating;
Leybold-Heraeus GMBH	Q16	Hg	3	15	5	2 Umbrellas and Nozzle
	Q20	Hg	3	20	8	2 Umbrellas and Nozzle
	Q30	Hg	2	0.6	40	2 Umbrellas
	WDS	Steam and Water	2	Atm.	2000 lit/hr	2 Nozzles; Steam ejector backed by water jet; pulls 2 torr.
						Large pump
<b>U.S.</b>						
Bendix Corporation (formerly Consolidated Vacuum Corporation)	GHG-10	Hg	2	2	2.5 l/s, Peak at 5	Umbrella and Nozzle
	G4	Oil	1	4.10 <sup>-2</sup>	5	Hickman, fractionating; Air-cooled
	GF20	Oil	2	0.1	26	Hickman, fractionating; Also air-cooled
	GF25	Oil	3	0.1	29	Hickman, fractionating; cooled version
Delmar Scientific Laboratories	Van Hesper	Hg	2	—	—	2 Umbrellas
General Electric Company	22DP100	Hg	3	10 <sup>-3</sup>	80	3 Umbrellas; 10 <sup>-14</sup> claimed with 2 traps
H. S. Martin and Son	M401310	Hg	1	—	—	2 Nozzles in parallel
	M401000	Oil	2	—	10	2 Umbrellas; Air-cooled

space which calls for good backing but gives fast pumping.

The Pumping Speed Column is basically, however, an index of pump size. If the pump is running efficiently, it is sheer size which counts. 100 l/s is, accordingly, the speed of the largest glass pump made. We usually regard 20-30 l/s as fast and small values indicate honesty in assessment, if nothing else. Actually glass pumps are very much individuals and two pumps of the same model can give quite different results. We also mention that the speed of an individual varies with the operating conditions so that backing pressure and inlet pressure, heater input and lagging, and condenser temperature should all be specified, preferably at their optimum values. These data are largely unknown and cannot be tabulated. Speed also varies with the gas being pumped. Dry nitrogen should, therefore, be used.

Water is used as the coolant except, as indicated in Table 1, in the case of some oil pumps which use air condensers.

## DETAILS OF SOME COMMERCIAL PUMPS;

### Umbrella Jets

Obviously it is of interest to see the detail of some of these different pumps. We shall then go on to consider briefly the theory of vapour jet pumping. In Table 1 we have classed the work fluid jets as formed by an umbrella or by a nozzle.

The line drawing of the Fisons pump (Fig. 4) illustrates a typical umbrella construction and shows how a pump can be stacked vertically. The umbrellas are mounted on the vapour delivery tube well inside the condenser which also surrounds the limb connecting with the forevacuum. This is a useful feature because jets must point towards the forevacuum and may, therefore, send vapour beyond the first condenser. This is especially true when, as here, the jets are in contact with the hot delivery tube. The work fluid vapour gets into each umbrella through

little holes drilled into the side of the central tube – a method which was introduced by Kurth in 1931 (Kurth 1931). The boiler is shaped to take an electrical well heater and this is probably the best method of heating.

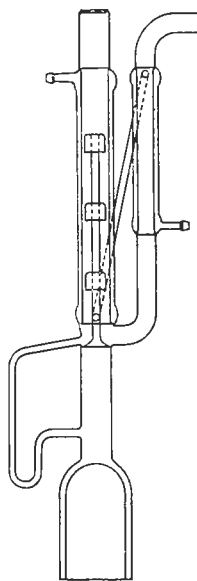

Fig. 4

Three-stage mercury diffusion pump  
(Fisons Scientific Apparatus Limited,  
Model PMD/3/2)

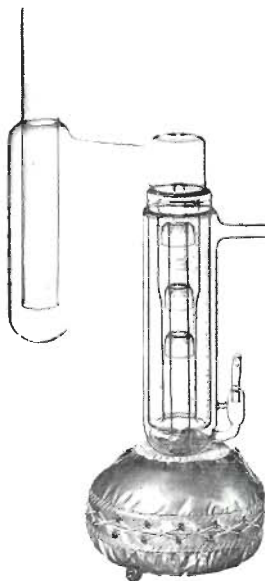

Fig. 5

Three-stage mercury diffusion pump  
(H. S. Martin and Son,  
Model M-401135)

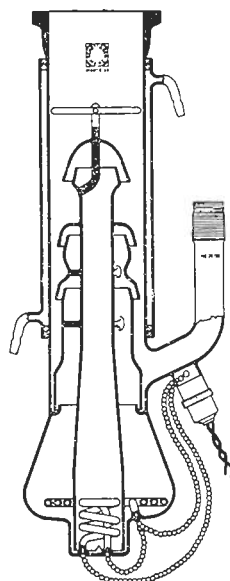

Fig. 6

Three-stage fractionating oil pump  
(Jena<sup>er</sup> Glaswerk Schott and Gen.,  
Model 3ö 100)

The little holes supplying the umbrellas can be seen on the photo, Fig. 5, taken out of the Martin Catalogue. A feature of this 3-stage pump is the provision of a vacuum jacket at forevacuum pressure. This takes the place of cooling the forepump lead and enables refrigerated water to be circulated without atmospheric moisture condensing on the outside walls. Such condensation creates a problem with the boiler. The Jencons Type 1 pump includes a similar feature. The speed of this particular pump increases 12% if the water temperature is lowered from 18°C to 0°C. The device at the side is simply a visual water flow indicator and we also see a typical re-entrant trap which, when immersed in liquid nitrogen, protects the high vacuum system from backstreaming mercury vapour.

The trap represents a source of inefficiency, not only in that it has resistance to flow but also in that the traffic of mercury into the trap represents a little diffusion pump working the wrong way round along the length of the connecting tube.

The vertical umbrella arrangement is particularly useful if we wish to bake the top half of the pump along with the protective traps and an ultrahigh vacuum system situated above the pump. The water jacket is drained for this purpose

and it is subsequently possible to reach base pressures in the  $10^{-12}$  torr region using only backed diffusion pumps. (Venema and Bandringa 1958; Venema 1959). The pump which Venema and Bandringa designed for this purpose is made by Quadrant Glass Company Limited. It is sometimes called the Philips pump after the Philips Research Laboratories at Eindhoven where the pump was developed.

The top jet of the Edwards EMG pump (which appears in Table 1) is also bakeable and base pressures in the  $10^{-13}$  torr region are claimed for this pump when it is run in conjunction with two bakeable traps.

#### FRACTIONATING OIL PUMPS

The umbrella arrangement is, of course, widely used in the construction of metal oil diffusion pumps. Rather than getting to the umbrellas through holes, the work fluid enters through annular slits. But there is nothing to prevent the use of such slits in glass, even for big pumps like the Jena 3Ö 100 which is shown in Fig. 6.

This pump, which uses oil, is over 3" wide inside and stands 1½ feet high. The 3-jet assembly is lowered in from above and sits on a shelf above the boiler. It also protrudes down into the boiler, dividing it into two interconnected parts. The purpose of this separation is to effect self-fractionation of the pump oil. Oil is not always a pure material. It collects condensates and the cheaper oils are also prone to continual transformation, turning into light and heavy fractions. The fractionating pump ensures that the heavier, less volatile fractions are reserved for first stage and the central compartment of the boiler is hotter than the outside one. The physical principle involved here is that escaping vapour is richer in light fractions than the oil which is left.

The light fractions from both boilers are continually returned to the outside boiler which only supplies the lower jets. The glass oil pumps in which fractionation occurs are, however, usually made with physically separated boilers.

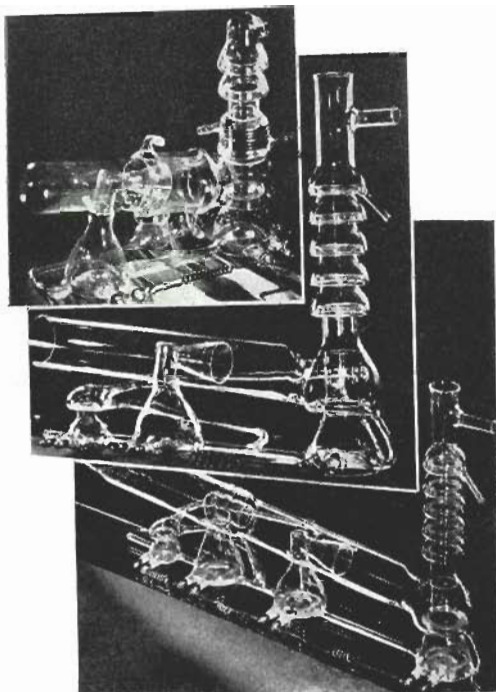

Fig. 7

Fractionating oil diffusion pumps (The Bendix Corporation)

Fig. 7 shows a collection of such pumps, taken from Hickman's paper in 1940 (Hickman 1940). The pumps are all listed as catalogue items by Bendix Corporation, formerly Consolidated

Vacuum Corporation. Before that, and at the time of Hickman's work, the manufacturers were called Distillation Products Inc. We notice that nozzles are being used so that the pump can no longer be stacked vertically. Some very early pumps had nozzles which pointed up, but this arrangement never gives good results. With nozzles, the boiler must therefore be placed so that work fluid can be piped to the nozzle from above or, as here, from the side.

We notice the following features, which are typical of oil pumps: There is a relatively large annular space on all stages, so that liquid oil cannot bridge the gap; there is a high supply rate to the vapour jets, occasioned by good heating and wide nozzles; and there are short supply lines to avoid condensation.

Two of these pumps only employ air cooling, which is sufficient for many oils. The water-cooled version of the 3-stage pump is shown in Fig. 8. It involves quite a bit of glassblowing.

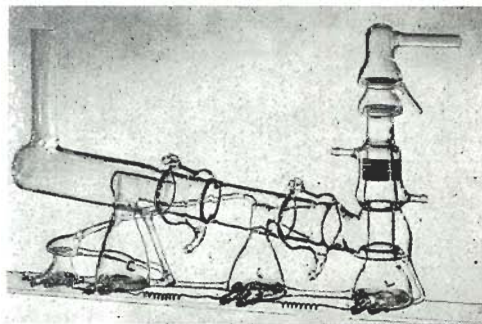

Fig. 8

Three-stage fractionating oil diffusion pump (The Bendix Corporation, Model GF25)

The inlet or high vacuum side is at the left. The forevacuum is connected at the top right and we notice that there are four boilers.

Let us see how the self-fractionation process occurs. Suppose the oil in the four boilers is all of the same composition and we start the pump running. The lighter fractions leaving the first boiler (right-hand side) are fractionated in the vertical column, which retains the lightest ends and removes them from circulation.

Light oil vapours from the second boiler are transferred on condensing to the first boiler. The loss of oil from the second boiler is made good by a flow of liquid oil from the first boiler. As pumping proceeds, more volatile impurity is transferred from the second boiler to the first than returns to it. Finally a dynamic equilibrium is set up in which the composition of vapour from the second boiler is the same as the composition of the liquid in the first boiler. The oil in the second boiler now contains fewer

light ends and gives a better vacuum (less back streaming and back diffusion).

A similar argument holds for the third boiler. The fourth boiler does not supply a jet; it is a sink for the heavier ends, just as the lightest ends are discarded in the alembics of the fractionating column. The fourth boiler is smaller and runs hotter than the other boilers. It serves to collect the tarry material from all stages. The lighter vapours are boiled out of the sink and returned to the other stages.

To summarize, light oil vapours are being continually transferred to the right. The lightest fractions end up in the alembics and the heavy residues collect in the left-hand boiler.

## EJECTORS

An ejector stage is often used to back the high vacuum stages. We have already mentioned that ejectors tolerate high backing pressures and they bridge the speed gap between diffusion pumps and backing pumps – that is, they take hold in the intermediate pressure range where these other pumps are slow.

Sometimes ejectors are assembled as separate pumps, as in the case of the mercury fore pump, Fig. 9, which appears in the Thermal Syndicate Catalogue. This interesting pump, which is made

in silica, was designed by the staff of Thermal Syndicate Limited in 1948 (Thermal Syndicate Limited 1948).

The narrow annular space between nozzle and condenser, coupled with grazing incidence between the vapour jet and the condenser constriction ensures that a good seal exists between inlet and outlet sides. The pump is clearly modelled on the water jet ejector but its operation is better likened to a steam ejector because the work fluid is compressible and the jet is supersonic. Originally the pump was designed to pull  $10^{-2}$  torr when backed with a water jet pump, the combination being intended to replace expensive rotary backing pumps.

Before passing on to a steam ejector, we give an example of a nozzle or ejector stage which is built into the same pump containing umbrella stages (Fig. 10). This mercury pump was designed by von Meyeren in 1950 (von Meyeren 1950) to be backed by a water jet pump pulling about 15 torr. Actually it is worth noting that the critical backing pressure beyond which the sealing action of a pump between the high and the low pressure sides begins to fail is never a sharp value. In general, breakdown occurs slowly and over a range of backing pressures determined, as we have said, by the working conditions and the gas being pumped. Under certain circumstances

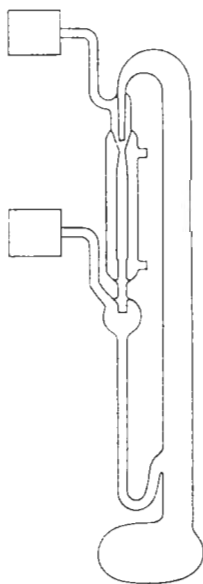

Fig. 9  
Mercury ejector pump  
(Thermal Syndicate Limited,  
Model S 1080)

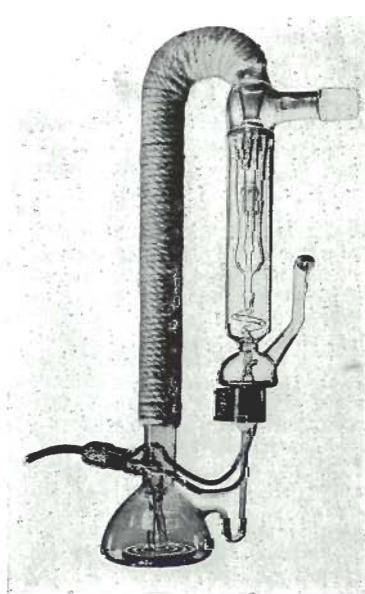

Fig. 10  
Three-stage mercury vapour pump  
(Jenaer Glaswerk Schott and Gen.,  
Model 3Q6)

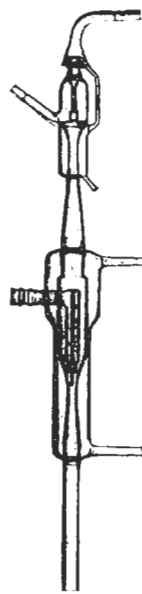

Fig. 11  
Steam ejector pump  
(Leybold-Heraeus GMBH,  
Model WDS)

the pressure at the high vacuum side may even oscillate regularly and in sympathy with the alternate occurrence of pumping and breakdown.

The device at the head of the return limb is not a booster stage but a condensate separator which purges work fluid of condensable vapours which have been pumped.

The Leybold steam ejector (top stage in Fig. 11) is shown backed by a water jet pump using an annular nozzle. Steam enters at the top right and passes both to the steam nozzle and also to the pump jacket, in which we would normally expect cooling water. The pump body is heated rather than cooled because adiabatic expansion beyond the nozzle can produce vapour temperatures at which ice is stable. Auxiliary heat input becomes necessary below 4 torr in these devices to prevent freezing.

As in a conventional diffusion pump, work fluid vapour is first expanded. But instead of condensing the vapour next, we simply shoot it through the narrow section across which there is an efficient seal to any counter movement. This part of the pump is called the diffuser and its design is critical. Beyond the constriction steam loses its kinetic energy and its pressure rises once more towards the outlet.

The inlet pressure of this ejector bottoms out at 2 torr, which is only about 15% of the saturated vapour pressure of water at room temperature. Multi-staging of steam ejectors can reduce the inlet pressure to as low as  $3 \cdot 10^{-2}$  torr. In contrast, the water jet pump cannot pump below the vapour pressure of water. This is because there is considerable lateral movement from the jet before it enters the diffuser. In any case, air which is always dissolved in ordinary tap water comes gushing out of the water jet as soon as it enters the low pressure region.

### JET PUMPING ACTION

We shall consider now just how it is that a vapour jet pumps. Although we can identify various processes which are involved, there is, as yet no complete theory for the diffusion pump. Over the years this has been a subject of great controversy and the theory remains as no more than a guide to what is essentially a practical subject.

With this qualification, let us see what can happen when we have a static gas such as air in contact with any moving surface. The moving surface may be a solid, such as steel, a liquid, such as water or a stream of another gas, such as steam, oil vapour or mercury vapour.

We find that motion is imparted to the air molecules, which tend to be swept in the direction of the moving boundary. This occurs regardless of gas pressure and boundary speed. Several effects which cause this can be identified. Some operate only at above about  $10^{-3}$  torr intake pressure. Others continue to occur in the region of molecular flow, that is, when the mean free

path of molecules being pumped becomes larger than the pump dimensions.

### MOMENTUM TRANSFER

The air molecules are in constant random motion and continually bombard the boundary. When the speed of the boundary becomes significant compared to the average molecular velocity of air, then air molecules rebound with a significant component of their momentum in the direction of boundary movement.

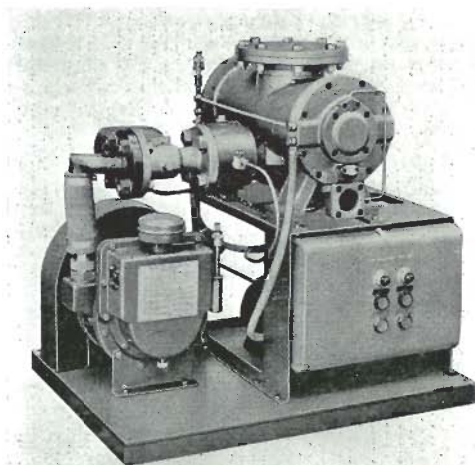

Fig. 12  
Turbo-molecular pumping system (Welch Scientific Company)

This effect operates at all air pressures and is utilized in the turbo-molecular pump. In this pump, invented by Gaede in 1913 (Gaede 1913a) air is moved along a 4 thou gap between a stator and a rapidly revolving rotor, which may turn at 8,000 r.p.m. The modern version of Gaede's pump is capable of achieving ultrahigh vacuum ( $10^{-9}$  torr) if there are several stages. Fig. 12

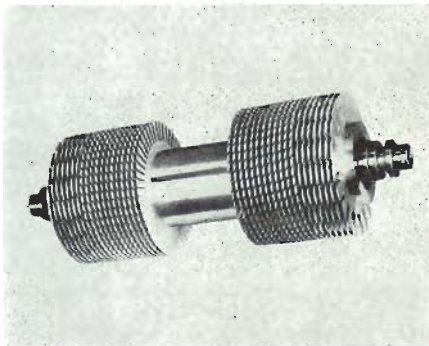

Fig. 13  
Molecular pump rotor (Arthur Pfeiffer GmbH)

illustrates a molecular pumping system manufactured by The Welch Scientific Company in which the turbo-molecular pump is backed by a conventional rotary oil pump. The rotor in these devices (Fig. 13) is deeply fluted and fits into a correspondingly shaped stator so that the area of moving boundary is large. The precise machining required is expensive and the pumps are very vulnerable to debris and corrosion, so one does not see them very often. They are relevant to the present discussion because they undoubtedly illustrate one of the mechanisms responsible for the pumping action of so called diffusion pumps.

### VISCOUS DRAG AND ENTRAINMENT

At high pressures, aerodynamic shear causes air movement in the desired direction even where no actual contact with the moving boundary has occurred. This ceases when the mean free path of the molecules being pumped falls to the region of the pump dimensions, so it only helps us above about 1 micron pressure. Viscous drag, nevertheless, occurs in many pumps, notably the water jet pump and steam and oil ejectors. Although this might appear to draw a distinction between diffusion and ejector pumps, the difference between these pumps is at best vague and frequently non-existent.

If the boundary is turbulent rather than smooth, air can be trapped and flushed away during its occlusion. In the familiar water jet pump, for instance, air can be seen to be emulsified and swept into the sink.

### SUCTION

If we hang a ribbon from the handle of a car door, we find that it does not flutter freely when travelling but that it is pressed on to the car body. This is because the density of a gas is a function of its velocity and the moving sheath of air next to the car becomes rarefied. As a result air is drawn in from undisturbed regions and presses on our ribbon. Air is also drawn out of the car if we open a small window – the rarefaction may be sufficient to make itself felt on the occupants' ears.

This balance between pressure energy and kinetic energy is demonstrated in the following experiment (Fig. 14): Air is blown sharply down a tube which bears, on its end, a flat disc. Paper or card which is held a couple of cm below the opening is sucked up – it is not blown away from the opening. This is because the air which is moving in the space between the disc and the card is below atmospheric pressure, so that the normal atmospheric pressure acting on the underside of the card pushes it up†.

This is also why blowing between two leaves of a book to separate them first parts them and then shuts them up again. Although other laws have been imperiously invoked to account for this, it is simply a manifestation of the principle in gas

dynamics that high velocity gives low pressure. The scent spray or atomiser is perhaps the commonest example and one can often notice the draught near to large air jets.

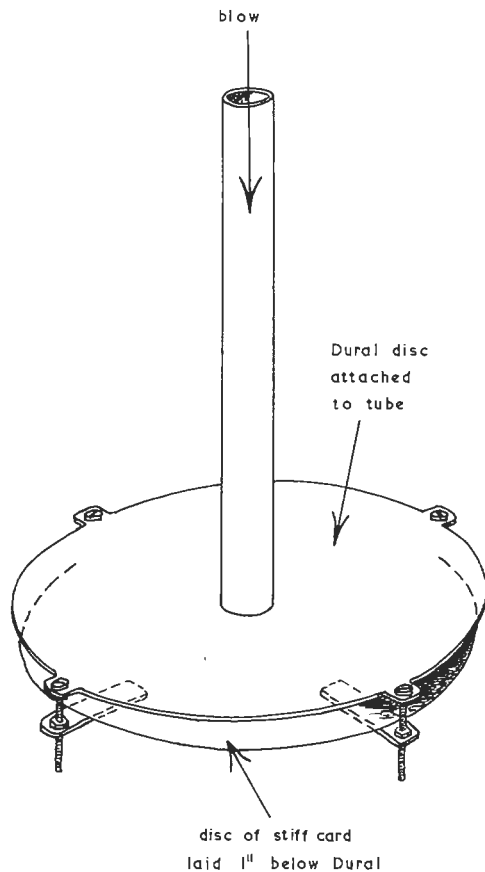

Fig. 14  
Experiment to show that the density of a gas is a function of its velocity

Pump vapour jets undoubtedly pump in the same way at high intake pressures, but this mechanism cannot continue in the region of molecular flow. It does, nevertheless, explain the way the pressure of gas varies in the jet of work fluid itself.

†The best effect is obtained by making the underside of the upper disc quite smooth and blowing on to fairly stiff, heavy card.

The isobars shown in Fig. 15 were recorded in the jet of a mercury diffusion pump by Alexander (Alexander 1946). To do this, a probe tube connected to a McLeod gauge was lowered into all regions of the jet. The isobars, therefore, refer to the partial pressure of air. On squirting mercury vapour, under a head of several torr into the pump body where the static pressure is  $6.6 \times 10^{-2}$  torr, velocity imparted to air molecules gives rise to a pressure as low as  $10^{-3}$  torr (first isobar).

After the initial expansion the mercury jet encounters more air molecules from the intake and loses velocity. Air pressure now rises and presently reaches the intake pressure (heavy isobar at  $6.6 \times 10^{-2}$  torr). Subsequently the pressure actually rises slightly above the value at which the forevacuum is maintained. Kinetic energy of the work fluid is now being converted back into pressure energy.

Similar rarefaction and compression is known to occur in steam ejectors. If the device is designed correctly, compression does not occur until, paradoxically, the jet reaches the expanding section of the diffuser. We also find that high velocities are built up in nozzles which have been designed so that gas flowing through them expands continuously.

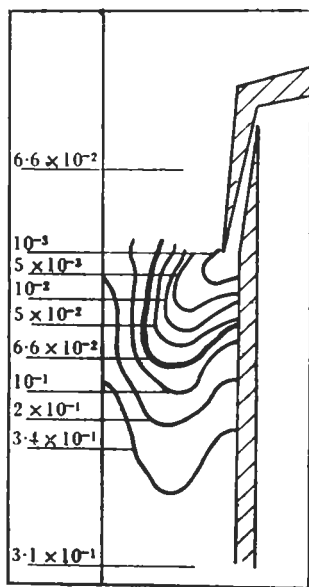

Fig. 15

Isobars in the region of the nozzle of a mercury vapour pump (Alexander 1946)

Referring to Fig. 15 again, if we extrapolate the isobars, we notice there is a falling pressure gradient in the pump body above the jet. This

cannot be due to suction at low pressures; it is the result of gas diffusion.

## DIFFUSION

When the air pressure is lowered to the region of molecular flow, viscous drag and suction no longer operate because the air molecules take no notice of each other.

They now reach the moving boundary by diffusion alone – that is the random movement of the individual molecules. The maximum speed with which air can be removed is determined simply by the rate of its arrival at the boundary and may be calculated either from Knudsen's formula for molecular flow through a circular hole in a thin plate or from the formula which involves the population density and rate of impingement. A value of  $11.6 \text{ l/s/cm}^2$  of aperture is then evaluated for air at  $20^\circ\text{C}$ . Actual pump speeds are always less and never reach more than half of this theoretical maximum, even in the best vapour pumps. This is because the moving boundary does not retain every molecule diffusing into it and, in any case, the moving boundary is not sharp. The ratio of actual speed to theoretical maximum is called the *speed factor*; if it turns out to be less than, say, 0.3 then we can be sure the pump is not running efficiently.

The foregoing perusal shows that there is no single primary process responsible for the pumping action of a vapour jet pump, although momentum transfer and diffusion are certainly concerned at all pressures. Our simple-minded picture is further complicated by the problems of making a vapour jet into a perfect moving boundary – the jet material always backstreams to some extent. And removal of work fluid and pumped gas is never completely effective – the pumped gas back diffuses to some extent.

## “DIFFUSION PUMPS”

We have seen that a pure momentum pump can be made, and it is logical to inquire if a pure diffusion pump can also be devised. This is, in fact, how so-called diffusion pumps originated. The simplest diffusion pump is a boiling kettle (British type!). If we leave it long enough, air is pumped from the space above the boiling water – if the kettle is sealed and cooled it is probably crushed by the atmosphere. Similar devices, of somewhat better efficiency, but again operating on a pure diffusion basis were designed by Gaede in 1913 (Gaede 1913b; Gaede 1915) who allowed gas to diffuse into a swiftly moving stream of work fluid through small holes. Although the efficiency of removal of work fluid and pumped gas was high in these devices, they were still very slow for the primary pumping process.

It was left to Langmuir (Langmuir 1916) to devise the first “diffusion” pump, as we know it. In 1916 he did away with the idea of small areas of contact between the work fluid blast and the

gas to be pumped and simply used an open jet for the first time. Pumping speed was enormously improved but notice that we now also have all the capabilities which have been discussed previously for molecular pumps and ejectors.

In this diffusion pump, work fluid is removed by a condensation process, hence the alternative name "condensation pump". The basic reason why the pump works is that the moving boundary stays reasonably well defined. This is the result of its great speed - Mach numbers considerably in excess of one may be calculated for the moving jet using the formulae of gas dynamics which we shall mention below. As a result, the molecules of work fluid which move out of the jet and away from our moving boundary represent a very small proportion. At Mach 1.2, for instance, this proportion only amounts to 4.4% and by Mach 2 it has fallen to as low as 0.2% (Alexander 1946). Unlike our boiling kettle, the work fluid now forms a compact entity.

The Schlieren photos of a mercury jet at three different boiler pressures shown in Fig. 16 were published by Nöller in 1955 (Nöller 1955) and they show how well-defined the boundary is. In these experiments the inlet pressure was  $10^{-3}$  torr. At higher inlet pressures, the jet loses definition and a shock wave, similar to that of gases arising after firing a gun, begins to appear. Correspondingly pumping action deteriorates. Some investigators hold that such shock waves, which are regions of sudden high density gas, are responsible for the seal across the pump. Actually one can see mercury jets by making them purple with a Tesla discharge and spontaneous flickering can sometimes be seen in a darkened room:† presumably this is occasioned by frictional charge up as vapour passes through the nozzle.

Another result of the high jet velocity in a diffusion pump is that momentum is readily transferred to gas molecules which find their way onto and into the jet. In fact if the jet were not moving very rapidly, its pumping action would become very slow as the inlet pressure fell and the viscous drag and suction effects ceased to operate.

#### QUANTITATIVE CONSIDERATIONS

Work fluid, then, will only transfer a large downward component of momentum to the pumped gas if the velocity of the work fluid is supersonic. This is because the average molecular velocity in a static gas becomes the local velocity of sound  $\alpha$  (which is greater than the static sound velocity  $\alpha_0$  cp Table 2) during adiabatic expansion. If, therefore, the velocity of the work fluid were appreciably subsonic, the jet would neither be

Fig. 16  
Mercury vapour jet at three boiler pressures  $p_0$ . Air pressure  $p$  surrounds the jet (Nöller 1955)

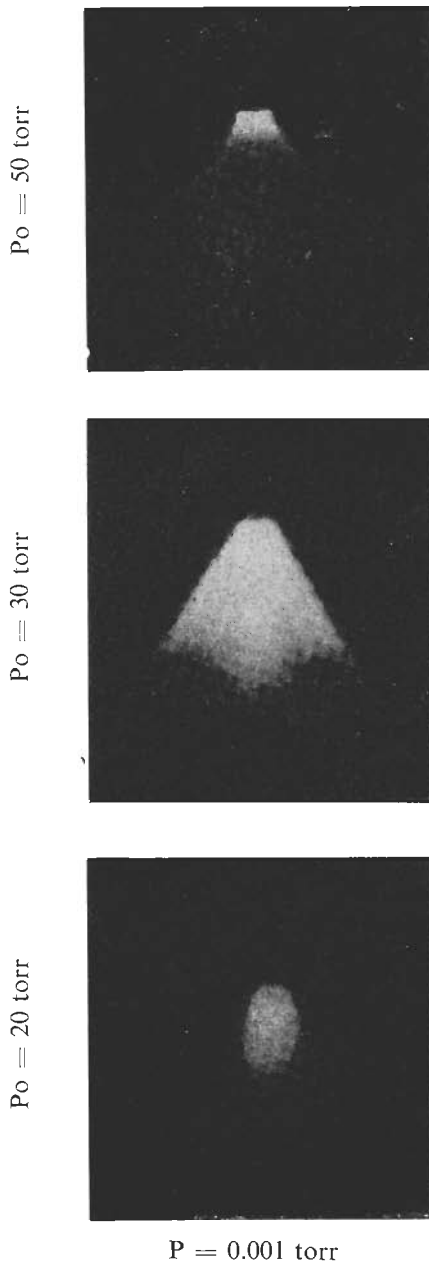

† Spontaneous discharges in disturbed mercury vapour were first noticed by Picard in 1676. They form the subject of numerous references in writings of the time.

Table 2 Formulae used in gas jet theory

$\gamma$  = ratio of specific heats       $p$  = pressure  
 $e$  = mass per unit volume (mass density)  
 $v$  = volume per unit weight (specific volume)  
 Subscript  $_o$  refers to initial, rest condition.

static sound velocity  $\alpha_o = \sqrt{\frac{\gamma p_o}{e_o}}$   
 for an adiabatic change of state  $p v^\gamma = \text{constant}$   
 local sound velocity during expansion  $\alpha = \sqrt{\frac{\partial p}{\partial e}}$

---

velocity of gas during free expansion into a vacuum  
 (propagation of a plane wave in a compressible fluid)

$$\begin{aligned}
 w &= \int_{e_o}^e \sqrt{\frac{\partial p}{\partial e}} \cdot \frac{de}{e} \\
 &= \sqrt{\frac{p_o \gamma}{e_o}} \cdot \frac{2}{\gamma-1} \left[ 1 - \left( \frac{p}{p_o} \right)^{\frac{\gamma-1}{2\gamma}} \right]
 \end{aligned}$$

---

velocity of gas flowing through a nozzle or orifice  
 (adiabatic expansion)

$$w = \sqrt{\frac{p_o}{e_o} \cdot \frac{2\gamma}{\gamma-1} \left[ 1 - \left( \frac{p}{p_o} \right)^{\frac{\gamma-1}{\gamma}} \right]}$$

weight of gas passing any cross-section  $A$  per unit time = constant

$$= A \sqrt{2g \frac{\gamma}{\gamma-1} \cdot \frac{p_o}{v_o} \left[ \left( \frac{p}{p_o} \right)^{\frac{2}{\gamma}} - \left( \frac{p}{p_o} \right)^{\frac{\gamma+1}{\gamma}} \right]}$$

---

Mach number =  $\frac{w}{\alpha}$

able to transfer momentum to pumped gas molecules†, nor would it be able to avoid spreading in all directions. For this reason we are interested in the conditions under which supersonic velocities may be obtained.

The theory of gas dynamics has been extensively developed in connection with high speed aircraft and rockets and it now seems clear that gases can attain highly supersonic velocities as an unaided result of their own free expansion. This view is, nevertheless, not universally held and has been challenged as recently as 1952 (Riemann 1952).

Some formulae which have been applied to the vapour pump are collected in Table 2.

The local velocity of sound  $\alpha$  is a function of gas pressure and density and we require to compare it with the actual velocity  $W$  attained by the gas molecules at any point during expansion;  $W$  may rise to a value which is several times  $\alpha$ . The ratio of these two velocities is the Mach number.

Two alternative expressions for the velocity which the gas attains may be applied. It is usually more logical to regard the expansion process as one of free expansion into a vacuum. From this expression we can find the pressure drop which is required for molecules to reach the velocity of sound. It depends only on  $\gamma$ , the ratio of specific heats, according to

$$\frac{p}{p_0} = \left( \frac{2}{\gamma+1} \right)^{\frac{2\gamma}{\gamma-1}}$$

where  $p$  is the pressure at any point during expansion and  $p_0$  is the initial pressure. We then find that mercury molecules attain Mach 1 when the pressure has fallen to 23% of its initial rest value. The corresponding figure for oil, which has a low  $\gamma$  value, is about 34%. These falls in pressure are obviously reached very soon after the work fluid has left the nozzle. They show that high Mach numbers are readily obtained but that there is still a small subsonic skirt from which lateral diffusion occurs. This region of the jet should be shielded and modern vapour pumps do, in fact, employ divergent nozzles rather than orifices pointing in the desired direction.

The alternative treatment considers the expansion process as a frictionless flow through a nozzle or an orifice into a region of lowered pressure. The gas velocity is again a function of the initial rest conditions of pressure and density, the ratio of specific heats and the local pressure during expansion. In a nozzle the weight of work fluid passing any cross-section per second must be constant and it becomes possible to evaluate the best nozzle dimensions for a given fluid working between given pressures at a given delivery rate.

†Phenomena encountered with high speed aircraft are analogous: if the aircraft moves at above the velocity of sound in the air surrounding it, then momentum must be transferred to every molecule encountered and a sudden increase in resistance to movement occurs.

This theory is used in the design of nozzles for steam turbines and it has been applied to steam jets *beyond* the nozzle in a treatment of the steam ejector (Stodola 1927; Dushman and Lafferty 1962). We find that continuous expansion can occur during passage through a convergent-divergent nozzle (Laval type) and that the velocity of sound is reached at the throat; if this has the correct cross-sectional area expansive flow beyond the throat is shockless. Supersonic velocities are again, therefore, readily reached. We refrain from going into detail.

#### DIVERGENT NOZZLE VAPOUR PUMPS

It is not clear whether the theory developed for steam nozzles is applicable to vapour jet pumps. Further, a clearly defined set of operating conditions must be assumed. Pump nozzles of the Laval type have, nevertheless, been designed and they lead to pumps for which satisfactory speed

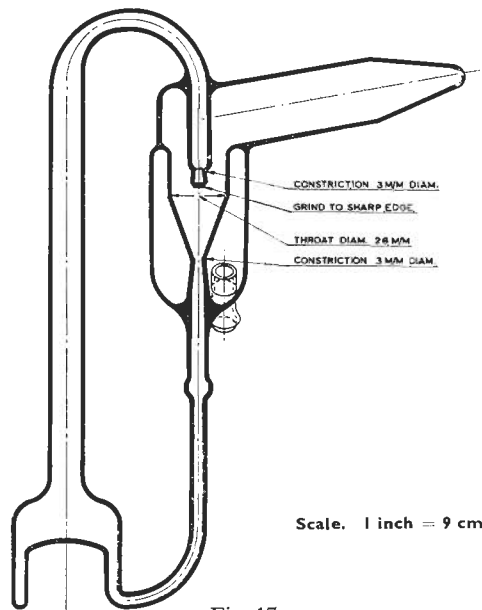

Fig. 17  
The Baldock pump

factors are obtained. Such a mercury pump is shown in Fig. 17. It was designed in 1948 by J. Pollard, working at the Services Electronic Research Laboratories in Baldock, Hertfordshire and has come to be known as the Baldock pump. We notice that the nozzle is of the convergent-divergent type, that the dimensions are precisely

defined and that the end is ground to a sharp edge; the nozzle forms a critical part of the construction and one assumes, according to one's beliefs, that supersonic velocities exist at all points in the vapour stream beyond the 3 mm constriction. The shape of the condenser has also been carefully considered to give good condensation efficiency. The wide annular space between the nozzle and the condenser means that good backing is required.

Although this pump has never been published, a good pump, like good news travels. The pump had already reached Australia when the author arrived there in 1955. It was being built from the drawing which is reproduced here by a German glassblower who, not inappropriately, believed he was blowing the Bulldog pump.

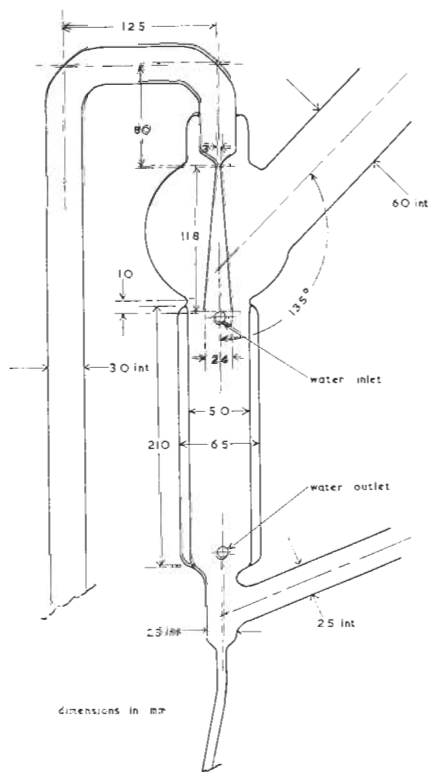

Fig. 18

Large divergent nozzle diffusion pump  
(Copley, Simpson, Tenney and Phipps 1935)

Divergent nozzles were actually used first by Crawford (Crawford 1917) who drew on steam engineering practice in 1917 and some quite large ones have been made and studied since. The large mercury pump in Fig. 18, which we

note also has a 3 mm throat in its nozzle, was designed using turbine theory by Copley and co-workers in 1935 (Copley *et al.* 1935). The annular space between the nozzle and the condenser was varied as well as the boiler pressure and speeds as high as 175 l/s were reported using dibutyl phthalate and 99 l/s using mercury. Predictably the pump is very sensitive to constructional variations and to operating parameters and we usually find that the speed for mercury lies in the region of 20 to 30 l/s. The pump is not too difficult to make and is useful for evacuating large laboratory apparatus. The 6 cm connecting tube should contain a suitably proportioned protective trap. The trap rapidly collects mercury and this fact alone suggests that the theory is not entirely borne out by practice.

Nozzle theory has also been applied to annular jets. Annular nozzles are harder to make, but

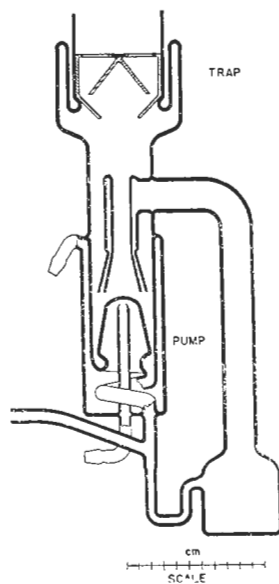

Fig. 19

Annular jet mercury diffusion pump (Bull 1941)

they extend the possibility of increasing the area of moving boundary without multistaging because the inner surface of the jet is exposed to intake gas molecules in addition to the outside. Fig. 19 shows an annular jet pump which was patented by Bull in 1941. (Bull 1941; Bull and Klemperer 1943). If we accept the speeds claimed (*viz.* 90 l/s at  $5 \cdot 10^{-5}$  torr beyond a high conductance trap) then it is the fastest pump of its size ever published.

The dimensions are all laid down precisely and again we have the convergent-divergent type of

nozzle geometry. This can be seen in the photograph, Fig. 20, which shows two such pumps arranged in parallel. The internal diameter of the annular jet at its throat is 19 mm and the throat width is  $1.5 \pm 0.2$  mm; the nozzle diverges for  $3\frac{1}{2}$  cm and reaches an annular width of 13 mm at its end. The end should be ground off square. Each pump is topped with a globular cold trap (Venema 1959) which suppresses the substantial quantities of backstreaming mercury. Each time the trap warms up, mercury is returned to the boiler. Traps of similar design which can, incidentally, be silvered, are made by Northern Scientific (York) and by Quadrant Glass Company Limited.

In common with the Copley pump, these pumps need good backing. They will give an ultrahigh vacuum in a bakeable apparatus connected above the globular trap without baking-out any part of the pump. In addition to providing low base pressures, the two pumps in Fig. 20 will also serve to maintain a low pressure when gas is

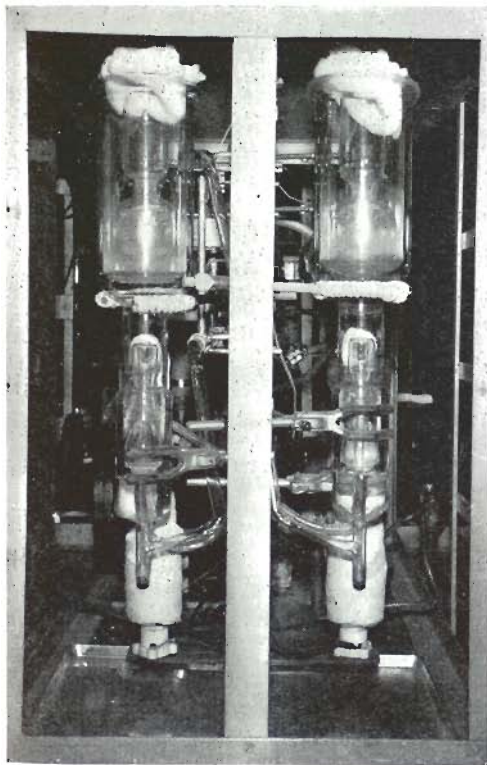

Fig. 20

Two annular jet mercury diffusion pumps

leaked into the system for any purpose, such as supplying an ionic source.

Long divergent or annular jet pumps are not commercially available as standard items – the straight forward umbrella construction is easier to make, cheaper, and serves for most purposes. The annular jet pump described is, nevertheless, frequently made and is a pseudo-catalogue item with Jencons (Scientific) Limited.

Annular jets also give good results with oil. In a single stage glass pump described by Pollard and co-workers (Pollard, Sutton and Alexander 1948), for instance, a speed of 80 l/s was obtained using glycerol vapour working against a backing pressure of 1 torr.

The high rate of backstreaming experienced with the annular jet mercury pump suggests that a second stage could usefully be added above

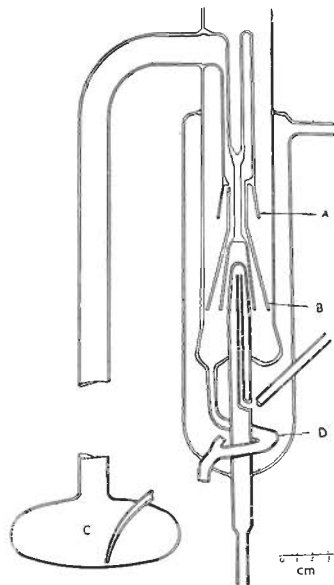

Fig. 21

Two-stage annular jet mercury diffusion pump (Haak and Vrátný 1959)

the large annular jet in order to suppress back diffusion of mercury vapour. Such a pump has, in fact, been made by Haak and Vrátný (Haak and Vrátný 1959) (Fig. 21), who fitted an umbrella jet A above the annular jet B and measured a speed of 40 l/s at the pump throat (20 l/s beyond their trap). The throat in their annular nozzle was 1 mm wide and the distance between the edge of the nozzle and the condenser was 2 mm. Although less mercury transferred to their trap, it is questionable whether the difficulties of making this type of pump are really justified.

Perhaps it is more logical to place the annular jet above, rather than below the auxiliary jet so that a wide space can be tolerated between the annular nozzle and the condenser wall. Such a pump was, in fact, built by S. Yorke in Bristol some twenty years ago and published in a paper by Gray in 1950 (Gray 1950). The dimensional drawing for an improved version appeared in Fusion earlier this year (Barr 1968). Fig. 22 shows a photograph of this beautiful pump, which is a

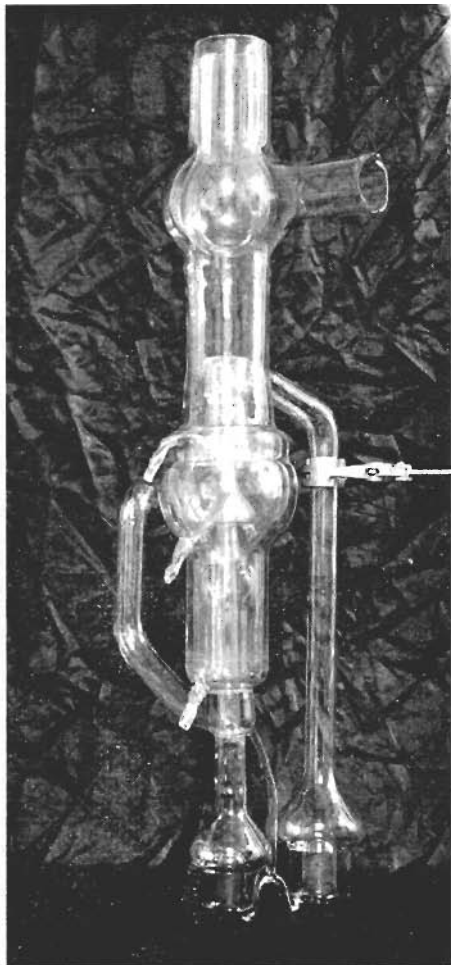

Fig. 22  
A Two-stage annular jet mercury diffusion pump  
(Gray and Yorke)

good example of how the subject of pumps affords an opportunity, all too rare nowadays, of mixing science with art.

#### REFERENCES

- Alexander, P., 1944. J.Sci.Inst. 21, 216.  
 Alexander, P., 1946. J.Sci.Inst. 23, 11.  
 Barr, W. E., 1968. Fusion. Journal A.S.G.S. 15, 44.  
 Bull, C. S., 1941. Brit. Pat. 552898.  
 Bull, C. S. and Klemperer, O., 1943. J.Sci.Inst. 20, 179.  
 Copley, M. J., Simpson, O. C., Tenney, H. M. and Phipps, T. E., 1935. Rev.Sci.Inst. 6, 265.  
 Crawford, W. W., 1917., Phys.Rev. 10, 557.  
 Dushman, S. and Lafferty, J. M., 1962. Scientific Foundations of Vacuum Technique (Wiley), p. 138.  
 Gaede, W., 1913a. Ann.Physik 41, 337.  
 Gaede, W., 1913b. Ger.Pat. DRP 286404, application dated 25th September, 1913.  
 Gaede, W., 1915. Ann. Physik 46, 357.  
 Gray, T. J., 1950. Disc. Far. Soc. 8, 331.  
 Haak, W. H. and Vrátný, F., 1959. Rev.Sci.Inst. 30, 296.  
 Hickman, K. C. D., 1940. J. App. Phys. 11, 303.  
 Ho, T. L., 1932. Physics 2, 386; Rev.Sci.Inst. 3, 133.  
 Kurth, E. K., 1931. See Dushman, S., J. Franklin Inst. 211, 708.  
 Langmuir, I., 1916. U.S. Pat. 1320874 dated 24th August 1916; J. Franklin Inst. 182, 719.  
 von Meyeren, A., 1950. Dechema Monogr. 14, 48, 57.  
 Nöller, H. G., 1955. Vacuum 5, 59.  
 Pollard, J., Sutton, R. W. and Alexander, P., 1948. J.Sci.Inst. 25, 401.  
 Reimann, A. L., 1952. Vacuum Technique (Chapman and Hall), p. 83.  
 Stodola, A., 1927. Steam and Gas Turbines (McGraw Hill), p.927.  
 Thermal Syndicate Limited, 1948. J.Sci.Inst. 25, 245.  
 Venema, A. and Bandringa, M., 1958. Philips Tec. Rev. 20, 145.  
 Venema, A., 1959. Vacuum 9, 54.  
 Volmer, M., 1920. See Yarwood, J., High Vacuum Technique (Chapman and Hall, 3rd edn. 1955), p.17. This classic pump was first made by Hanff and Buest, Glassblowers, Berlin, to the specification of Prof. Volmer, Hamburg University.

*\*The subject matter of this paper was given as a talk by Dr. D. Klemperer at the 1968 Symposium at Lytham St. Annes.*

*On behalf of the Society we thank him for extra work involved in the submission of the material for this publication. Copies are available at 5/- each.*

**kilns**

We have been making electric furnaces etc., since 1921, for glass workshops, laboratories, research and all production purposes.

**ovens**

to suit your own  
requirements

**furnaces**

**lehrs**

Some standard sizes but 80% are built to "special" shapes, styles, sizes to suit individual requirements—but at attractive prices and good deliveries. With or without fans, switchgear, instruments. Have your job tailored by the specialists

**catterson-smith**

R. M. CATTERSON-SMITH LTD. (Dept. SG), Exhibition Grounds  
WEMBLEY

Telephone

01-902 4291

## SECTION ACTIVITIES

### Western Section

The October meeting was held at the University of Cardiff when Mr. I. C. P. Smith a member of the section travelled from Sherborne, Dorset, to give a paper on "Air gauging methods".

Some visitors were among the 19 present and it is suggested that some of these might be encouraged to join the Society.

Mr. Smith's talk was based on his publications on the subject which have appeared in the Journal, and various types of jets shown were used for the calibration of the two-flow meters which were exhibited.

Jet shapes and other possibilities were considered which might lead to inaccuracies in the method and the talk was followed by a long question time. We thank Mr. I. C. P. Smith for his interesting talk and are also grateful to Mr. E. Medic and the University of Cardiff for providing facilities for the evening.

In November there was some misunderstanding over dates and as a result the visit to the D. A. Jones Sign Works was duplicated. Mr. Jones who is the Section Treasurer, gave a full description of his methods of manufacturing signs starting with the breakdown of the design to suitable lengths and the preparation of templates on asbestos paper to achieve accurate bending. He gave a demonstration on bending a 2ft diameter letter O with the aid of a long ribbon burner. Bending is then followed by acid cleaning of the interior surface, drying with hot air free from oil vapour, using glass balls as an aid to coating the tube wall with binder and subsequently dusting in the required fluorescent powder. Electrodes are then sealed in after which the sign is pumped, filled and finished. In this part of the process there are three stages: first a high voltage discharge is used at reduced pressure to heat the sign and remove most of the gas from the walls, the temperature being judged by paper slips stuck on the glass.

In the second stage a further gas clean-up is achieved by a discharge in helium after which the sign is finally filled to the correct pressure with neon or argon and sealed off.

This very interesting and practical talk took place at Mr. Jones' own glassworking premises and much of his equipment was open to inspection.

The Section thanks him for his hospitality.

**Future meetings are as follows:—**

27th Jan. 1969 - Section A.G.M.

February - Mercury Discharge tubes  
by Mr. M. Locke

March and April To be notified later

May - - Burners, by Mr. N. Lowde

June - - Works visit to Messrs. Jencons

Mr. M. Locke of the University of Bristol has agreed to display the Jobling award and replica at the Section A.G.M. This trophy was presented to him at the Lytham St. Anne's Symposium in September 1968.

### Thames Valley Section

The Section news sheet *Imprimature* has been revived and in No. 8 reference is made to a talk given by Mr. R. E. Bower of Yorke and Partners on the use of diamonds in the glass industry. Mr. I. C. P. Smith has also given a talk on Mathematics for the Glassblower, and the Section A.G.M. took place on the 24th October at A.W.R.E., Aldermaston.

All these meetings were well attended but more would be welcome.

Mr. Darvall and Mr. Noad gave a talk and glassblowing demonstration to the Institute of Supervisory Management at Lansing in Bagnol, Basingstoke.

Mr. J. Price has been elected to the Board of Examiners in place of Mr. D. Saxton.

### Future Meetings

**Thursday, 2nd January**

*Glass Working Machines*

By Mr. C. H. Glover of Heathway Machinery Co. Ltd.

At Reading University Chemistry Department.

**Thursday, 6th February**

*Technical Report Writing*

By Mr. M. Deere of Reading University.

At Reading University Chemistry Department.

**Thursday, 6th March**

*Section A.G.M. and Workshop Session*

At Reading University Chemistry Department.

**Thursday, 3rd April**

*Some aspects of development and production of Cathode Ray and Geiger Muller Tubes*

By M. O. Bartle of 20th Century Electronics Ltd.

At Reading University Chemistry Department.

**Thursday, 1st May**

*Informal talk on glass working equipment*

By Mr. Williams of Jencons Ltd.

At Oxford University Clarendon Laboratory.

### Southern Section

Extracts from *News Bulletins* Nos. 10 and 11.

### October Meeting

The Southern Section opened its 1968-69 programme with a bang.

The bang was provided by Mr. Cescotti, assisted by Mr. Forbes both of W.S.A. Engineering Ltd. The subject of Mr. Cescotti's talk was 'Burners and Flame Technology'.

A mountain of equipment had been transported to Q.E.C. which included cylinders of air, oxygen, propane and hydrogen; various types of burners and banks of needle valves. All this was set up in readiness for the arrival of our members.

Not exhausted by these efforts Mr. Cescotti talked to us for almost two hours continually demonstrating his remarks with the use of various apparatus. Though Mr. Cescotti talked in a jocular manner he was able to impress upon us, where necessary, the dangers involved.

The blackboard also came in for quite a lot of

use. Mr. Cescotti illustrated by this means flame speeds and the many differences between town gas and natural gas.

The whole talk was centred around the methods of using natural gas, a subject that cannot fail to interest every glassblower in the not too distant future. With this in mind it is surprising that, although Mr. Cescotti spoke to an almost full lecture theatre, the attendance from Society members was not nearly as good as it should have been. There were 44 present, of which around 25 were Society members.

The essence of Mr. Cescotti's lecture is contained in his publication *Burners and Flame Technology*. Copies of this can be obtained from W.S.A. Engineering Co. Ltd., 5-9 Hatton Wall, London, E.C.1., price £2 2. 0d. plus 1/6 postage.

#### *November Meeting*

Mr. T. Parsell, the Southern Section Chairman, introduced Dr. L. Oldfield to about 30 members: an improvement on the recent attendance at the meetings.

Dr. Oldfield started her talk by remarking that she had noticed that the subject was *The Properties of Glass*; however if she were to undertake this task we should be there for a fortnight. Therefore, Dr. Oldfield said she would confine her talk to *Properties of Glass used in the Lamp Industry*.

Some of the properties required under this heading are transparency, ability to maintain a vacuum, ability to make hermetic seals with metal

conductors, ease of shaping: these are the basic factors of glass for use in lamps.

In the case of the household lamp, made on a ribbon machine, two glasses are used; soda lime for the bulb, lead for the pinch that seals the wires. Soda lime glass quickly turns brown when used for sodium lamps, therefore this glass is lined with a borate glass which is not affected by sodium. A sample of this tubing was passed around: in order to demonstrate the point part of the borate glass had been etched away leaving half the inside of the tube lined and the other half soda lime. The lined portion had remained clear and the unlined portion had turned brown when subjected to sodium attack.

It was interesting to note that in addition to Sodium, Neon and Argon are also used in these tubes. The Argon is a starter for the Neon and the Neon is, in its turn, a starter for the Sodium.

#### *Hints and Tips*

Many people who have bought diamond wheel cutting machines have complained that they soon lose their cutting properties. A couple of light cuts into a piece of greenstone will restore the edge.

Greenstone can be obtained from leading glassblowers' suppliers.

Have you any useful tips? Of course you have! Write them down let me have them so that others may benefit.

T. J. MAPLE

## ***Skilled Scientific Glassblower***

required for vacuum electronic tube work. Experience is desirable on bench and lathe work, also glass-metal seals. Consideration would be given to an enthusiastic semi-skilled man. Good salary to suitable applicant.

**telephone Lodge Hill 2121**

# CHANGING TO NORTH SEA GAS!

---

WE HAVE AN EXTENSIVE RANGE OF NATURAL GAS BURNERS, MAINLY FOR MACHINE USE, BUT SOME ARE EQUALLY SUITABLE FOR BENCH WORK.

WITHIN THE LIMITS IMPOSED BY THE GAS ITSELF WE ARE PREPARED TO DESIGN AND PRODUCE ANY BURNERS FOR WHICH THERE IS A REASONABLE DEMAND

## QUADRANT

ENGINEERING COMPANY LIMITED

IMPERIAL WORKS, PERREN STREET, RYLAND ROAD, LONDON N.W.5.

Telephone 01-485 5516

# QUARTZ FUSED PRODUCTS LIMITED

RONEC WORKS · GOVETT AVENUE · SHEPPERTON · MIDDLESEX · WALTON-ON-THAMES 23870

*have vacancies for:—*

A **qualified Grinder** (must be able to work conical interchangeable Joints and Ball and Socket Joints to British Standard Specification).

An attractive commencing salary will be paid. Guaranteed annual salary review.

Existing holiday arrangements respected.

Excellent working conditions in completely new factory.

This is an opportunity to join an expanding Company.

Applications which must be in writing should be addressed for the attention of the Managing Director and will be treated in the strictest confidence.

# Advanced Techniques to Guard your Budget and Speed Production

THE  
PORTABLE

**'CUTANGRIND'** Machine with  
DIAMOND WHEELS



For every form of  
Cutting and Grinding  
Glass and Silica tubing  
(6in. or more)

Geological samples  
attachment (for slicing)

Ceramics, Refractories

Concrete, Tungsten

Carbides

Solid State Materials, etc.

Size : 17in. x 17in. x 12in.

Weight : 46 lb. net

Motor :  $\frac{1}{4}$  h.p. Capacitor

Fitted with 5in. Diamond saw with adjustable height control, depth of cut  $1\frac{1}{2}$ in.  
(3in. by revolving) Face and peripheral wheels interchangeable

ALL PARTS RUSTLESS NO SPLASHING MANY VERY SATISFIED CLIENTS  
ECONOMICALLY PRICED

Made by experts with 20 years' unrivalled knowledge in the manufacture and uses  
of diamond impregnated saws, wheels and drills

**FOR PULVERIZING, ANALYTICAL — PRODUCTION**

A.G.S. MACHINES all with Agate working surfaces

CONTINUOUS CONE GRINDER MORTAR MACHINE MICROMILL  
DIAMOND TOOLS FOR ALL PURPOSES

Write for catalogue to

**AGATE & GENERAL STONECUTTERS LTD**

**25 HATTON GARDEN, LONDON, E.C.1**

Telephone : EDGWARE 2558

For all your **GLASS CUTTING, REAMING, GRINDING** or **DRILLING** problems consult

## **F. Yorke & Partners Ltd**

Highbridge Wharf  
Eastney Street  
Greenwich, S.E.10

Telephone : GRE 6215-6

who are the sole agents in the U.K. for **DIAMANT BOART S.A.**, Brussels  
*Europe's leading Diamond Tool Manufacturers*



**FOR YOUR TOOLS  
AND MACHINES**  
CONSULT US

## **H. Baumbach Glassblowing Tools**

**12 BLACK PRINCE CLOSE : BYFLEET : SURREY**

Telephone: Byfleet 43705

# R W Jennings & Co Ltd

Main Street, East Bridgford, Nr. Nottingham

Telephone East Bridgford 463/4

The Popular

**"LESCO" MULTI TURRET GLASSBLOWING TORCH**

Patent no. 900827

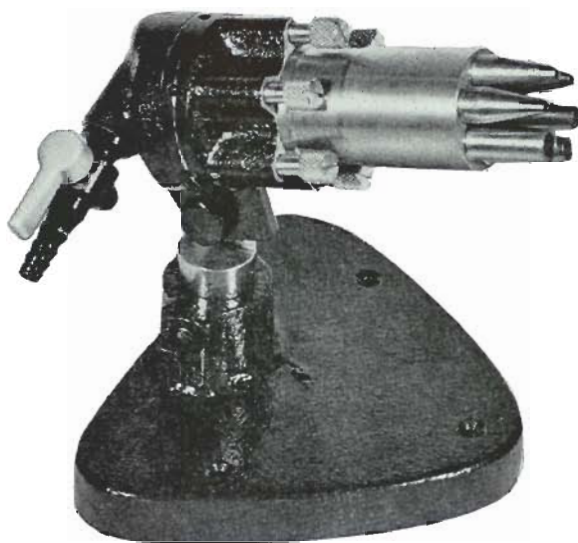

Oxy-Natural/Propane  
Gas Model

**£33 10 0**

Oxy-Town  
Gas Model

**£27 10 0**

★ **IMPROVED DESIGN**

★ **GAS BOARD APPROVED**

★ **INTRINSICALLY SAFE**

*Full details on request*

# Burners and the Advent of Natural Gas

As natural gas becomes available to more and more countries we are proud to announce our new and revolutionary development of Bench Burners and Hand Torches for Natural and Propane Gas incorporating two very important features:—

- a smooth flame that never breaks
- perfect flame adjustment from pinpoint to large blast

## Hand Torch:—

for propane gas/natural gas, popular design, separate gas, air and oxygen feed, with cone burner head; also this model incorporates the new stabilising feature.

Fully suitable for operation on traditional town gas, if required or necessary.

Catalogue No. :	141 a S-P/E	141 b S-P/E
Jet Bore:—	4 mm £28	7 mm £29



## Bench Burner:—

Thuringian model, with 3 interchangeable nozzles for connection to propane or natural gas, air and oxygen, separate gas feed to burner head, with perfect flame formation, quite similar to that produced by town gas, ensured by a special stabilising method.

With the aid of this new type of burner, all difficulties hitherto encountered in work with propane or natural gas can be easily overcome.

The burners also readily operate on traditional town gas.

Catalogue No.:	101 S-P/E	103 S-P/E	105 S-P/E
Jet Bore:—	6 mm £31	9 mm £33	12 mm £41

The range is completed by noiseless burners type "Zenit", equipped with our special flame stabiliser; they are suitable for connection to propane gas/natural gas and air, propane gas/natural gas and oxygen or propane gas/natural gas, air and oxygen

Catalogue No.:	114/1 - P/E	New design
	size a: £128	size b: £142

can now be used with gass/air for working soda.

## L. RICHOUX CO. (LONDON) LTD.

66-70, FINSBURY PAVEMENT LONDON – E.C.2.

Telephone: Monarch 2234/5

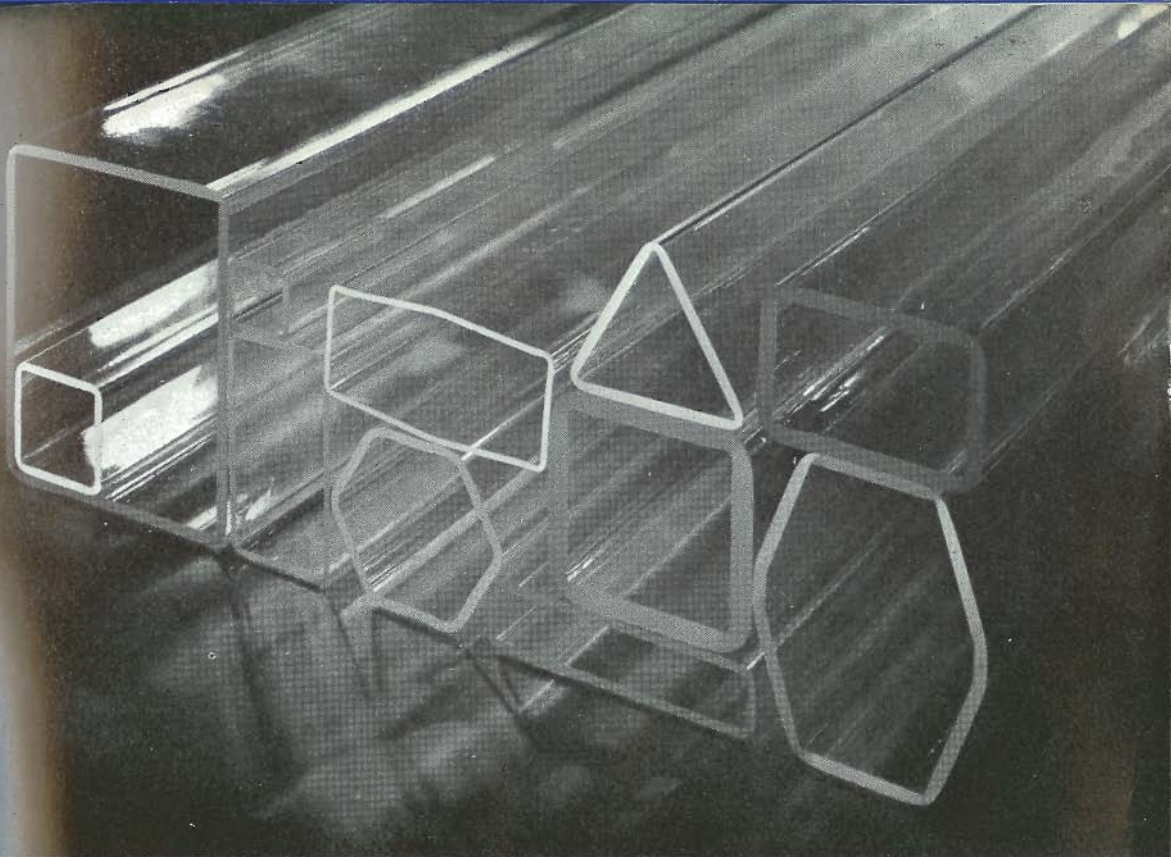

## highest purity transparent quartz glass ..and the best round tubes too!

Quartz glass from Engelhard Hanovia has the highest purity obtainable. It is transparent to ultra violet and infra-red light and will not interfere with the outcome of fine analysis. Other essential features are resistance to chemical attack, thermal shock, high temperatures and near perfect dielectric properties. This top grade material is available from comprehensive round tube stocks, or in a wide range of standard and custom-built Apparatus for Science and Industry.

We are the U.K. stockists and fabricators of all Hereaus materials including Heralux, Herasil, Suprasil, Rotosil and Infrasil.

Descriptive booklet requests and enquiries to:  
Quartz Division,

**ENGELHARD HANOVIA LAMPS**

Bath Road Slough Bucks Tel: Burnham 4041



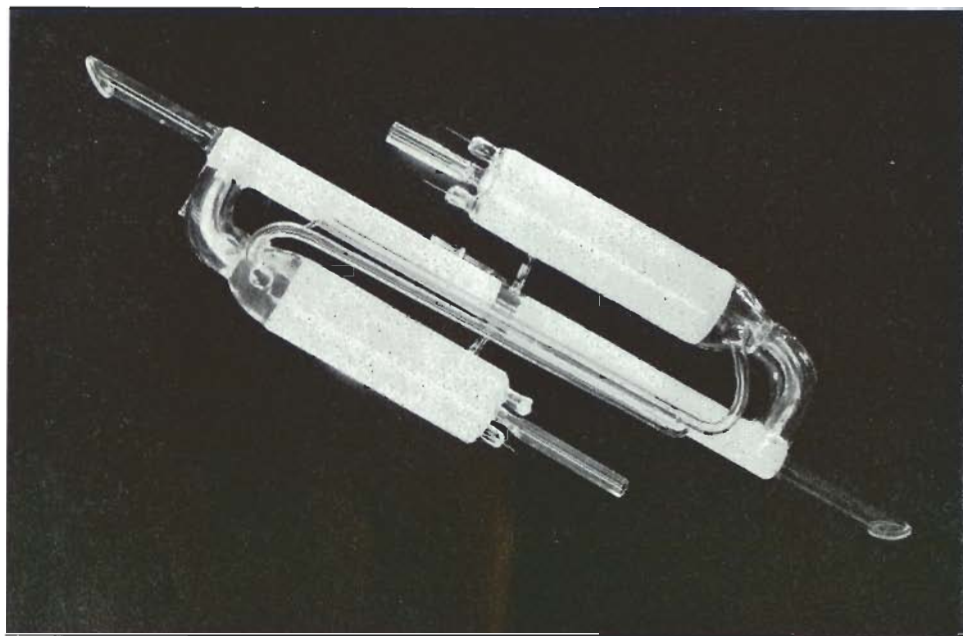

**For the 'UNUSUAL' in vitreous silica—**

**W. YOUNG, (fused silica)**

P.O. Box No. 39,

Hemel Hempstead,

Hertfordshire. Tel. 3984

**gas laser specialist**

**on site repairs and fabrications**

**standard and custom built apparatus**

# DIAGRIT TAPER GRINDING TOOLS

FOR LABORATORY  
GLASSWARE & CERAMICS

The simplest, cleanest and most effective way of producing accurate male and female tapers in glass and ceramics at one tenth of the previous operation time. The secret lies in the steel core coated with diamonds in a spiral pattern, giving a reamer life of between 3,000 and 6,000 bores according to the accuracy of the preformed joint.

Diagrit range of diamond taper tools covers all standard sizes and includes tools designed by us to suit special applications. Send for our catalogue showing the comprehensive range of diamond tools. Our Technical Department is available to advise you

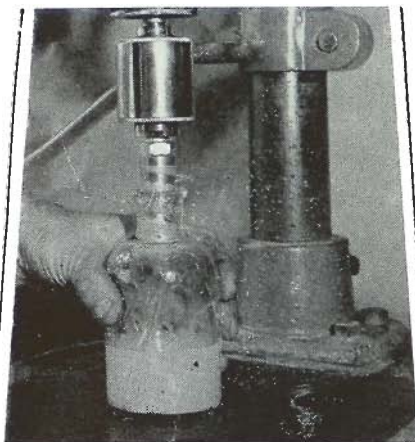

*Taper reaming a 500 cc bottle to size B24. A badly chocked bottle will be completed in 5-10 seconds*



*Taper reaming a borosilicate glass desiccator lid, size B34, at the works of Jencons (Scientific) Ltd., Hemel Hempstead. This operation is completed in only a few seconds. Tools can be supplied to both drill and ream out the hole in one operation*

DIAGRIT ELECTROMETALLICS LTD.  
STAPLEHURST, KENT.  
Phone STAPLEHURST **662**

THE WISE GLASSBLOWERS SAW —

# FANTASTIC TYSLIDE

GRINDING — PROCESSING — SAWING

- Simple
- Uncluttered.
- Simply superb.
- A scientific instrument of a machine tool, for the glassworker.
- Alloy machined working surface — Integral suds pump (shown).
- Rise and fall of saw blade controlled by front adjuster wheel.
- Cross fence simply adjusted for angle cutting (shown) or for removal.
- Forward and back movement of work plate, as well as locked position availability.
- Cuts tubing lengthwise by using easily attached rip fence.
- Glass or ceramics.
- Easy change over from sawing to grinding.
- Many other virtues.
  - Slitting
  - Slotting
  - Slicing
  - Sawing



**JENCONS** of course

**The Glassblowers Centre, Hemel Hempstead, Hertfordshire.**